



Food Cartology

Rethinking Urban Spaces as People Places

Urban Vitality Group
Planning • Economics • Consulting



Acknowledgements

The Urban Vitality Group thanks the following people for their input and assistance to the Food Cartology project.

Food Cartology Technical Advisory Committee

Alma Flores, City of Portland, Bureau of Planning

Clark Henry, City of Portland, Bureau of Environmental Services

Ken Pirie, Walker Macy

Kimberly Schneider, Commissioner Sam Adams' Office

Lisa Libby, Commissioner Sam Adams' Office

Lynn Knox, City of Portland, Bureau of Housing and Community Development

Madeleine Mader, City of Portland, Bureau of Housing and Community Development

Suzanne Paymar, Hacienda Community Development Corporation

Sarah Chenven, Mercy Corps Northwest

Cristina Stella, Ecumenical Ministries of Oregon Interfaith Food and Farms Partnership

Ronda Fast, City of Portland, Bureau of Development Services

Mark Gearheart, Property Owner- Sellwood Antiques

Nancy Chapin, Alliance of Portland Neighborhood Business Associations

Lizzy Caston, LAD Communications

Hindi Iserhott, City Repair

Ken Yee, Multnomah County Health Department

Sunny Souriyavong, Food Cart Owner, Sawasdee Thai Food

Nancye Benson, Food Cart Owner, Moxie Rx

Kevin Sandri, Food Cart Owner, Garden State

Andrea Spella, Food Cart Owner, Spella Caffè

Special thanks to the faculty advisors who provided guidance on the project

Ethan Seltzer

Sy Adler

Jennifer Dill



Hannah Kapell

Peter Katon

Amy Koski

Jingping Li

Colin Price

Karen Thalhammer



Table of Contents

Chapter 1: Introduction

Project Goals	6
Study Questions	7
Food Cart Industry in Portland and Elsewhere	8
Regulatory Issues	10

Chapter 2: Methodology

Food Cart Definition	11
Literature Review	11
Technical Advisory Committee	11
Regulatory Session	12
Industry Overview	12
Site Analysis	13
Interviews	14
Cost of Doing Business Comparison	14
Study Limitations	14

Chapter 3: Site Analysis

Downtown	16
Mississippi	18

Sellwood	20
Cully	22

Chapter 4: Findings

Findings	24
Neighborhood Livability	25
Community Economic Development	30
Cost of Doing Business Comparison	35

Chapter 5: Recommendations

Criteria	37
Identify additional location for food carts	37
Increase awareness of informational resources	38
Promote innovative urban design	39

Appendix

A: Regulatory Session Attendees
B: Survey and Inventory Instruments
C: Interviewee List
D: Team Profiles

Executive Summary

The Urban Vitality Group (UVG) partnered with the City of Portland, Bureau of Planning to study the effects that food carts have on street vitality and neighborhood livability. The number of food carts within the city seems to be growing, while the City lacks sufficient knowledge about the industry to guide policy. The purpose of the study was to assess the benefits and negative consequences of allowing food carts within the city and to ascertain what economic opportunities may be offered by food carts, especially for low-income and minority entrepreneurs. The findings indicate that food carts have significant community benefits to neighborhood livability by fostering social interactions, walkability, and by providing interim uses for vacant parcels. Additionally, carts provide good employment opportunities for immigrants and low-income individuals to begin their own businesses, although there are significant barriers to continued stability and success. The City's support of the food cart industry can advance the key public values expressed in VisionPDX and benefit all Portlanders.

To understand the economic and social implications of Portland's growing food cart industry, the project's goal was to answer the following questions:

- **Neighborhood Livability:** What effects do food carts have on street vitality and neighborhood life? What are the positive and negative impacts of food carts on the community?
- **Community Economic Development:** To what extent do food carts serve as an entry-point into long-term business ownership? Do carts provide beneficial economic opportunities for residents of Portland?

UVG assembled an extensive body of information through literature review, primary data collection, and stakeholder input. Primary data collection efforts included: surveys of cart owners and neighboring businesses; an intercept survey of pedestrians around the study sites; an online public survey; site and cart inventories; and interviews of these groups, as well as other organizations that play a role in managing or supporting food carts as a micro-enterprise. These data informed a comparison of the start-up costs between a push cart, stationary mobile cart, and small storefront business. UVG studied four food cart cluster sites in depth, located in downtown, Sellwood, Mississippi, and Cully neighborhoods.

Findings

The following key findings are based on the results of the data collection, as well as consultation with experts:

1. Food carts have positive impacts on street vitality and neighborhood life in lower density residential neighborhoods as well as in the high density downtown area.
2. When a cluster of carts is located on a private site, the heightened intensity of use can negatively impact the surrounding community, primarily from the lack of trash cans.
3. A cart's exterior appearance does not affect social interactions or the public's overall opinion of the carts; seating availability is more important for promoting social interaction than the appearance of the cart's exterior.

Executive Summary

4. The presence of food carts on a site does not appear to hinder its development.
5. Food carts represent beneficial employment opportunities because they provide an improved quality of life and promote social interactions between owners and customers.
6. Despite the beneficial opportunities that food carts can provide, there are numerous challenges to owning a food cart.
7. While many food cart owners want to open a storefront business, there is a financial leap from a food cart operation to opening a storefront.
8. Food cart owners do not frequently access small business development resources available to them, such as bank loans and other forms of assistance.

Recommendations

Based on the data collected, UVG's recommendations promote the benefits of the industry and mitigate negative impacts. The recommendations were also selected based on their ability to advance the key public values expressed in VisionPDX – including community connectedness and distinctiveness, equity and access, and sustainability – and provide sound guidance to potential considerations for the Portland Plan.

1. Identify additional locations for food carts.
2. Increase awareness of informational resources for stakeholders in the food cart industry by connecting them with existing programs.
3. Promote innovative urban design elements that support food carts.

Public authorities need to recognize and preserve any community places, regardless of their use or appearance, and encourage a variety of businesses by supporting small, independent businesses that in turn are better able to provide other characteristics such as permeability and personalization of street fronts - Vikas Mehta (2007)



Introduction



The food cart industry appears to be expanding in Portland - in number, geographic location, and in the public's consciousness. A thriving food culture is evident in the long lunch lines on a sunny day, numerous food-cart blogs and web sites, as well as local and national media attention¹. Recently, Willamette Week hosted an "Eat Mobile" event to celebrate food cart culture in Portland. More than 800 hungry fans attended the event, and food quickly ran out.² While the industry has thus far operated with minimal controversy, the media has covered some conflicts between food cart owners and storefront business owners, some of whom perceive carts to be unfair competition.³

In January 2008, the Urban Vitality Group (UVG) teamed with the City of Portland, Bureau of Planning to undertake an exploratory study of Portland's emerging food cart industry. UVG's research questions regarding the effects of food carts on neighborhood livability, as well as the industry's potential for creating beneficial entrepreneurial opportunities, are particularly relevant to the values identified by Portlanders in the VisionPDX project – community connectedness and distinctiveness, equity and access, and sustainability. The findings and recommendations of the Food Cartology project provide insight into what role food can play in promoting these values as the city updates its Comprehensive Plan and Central City Plan.

Project Goals

The Food Cartology project is a study of the state of the food cart industry in Portland, as well as an investigation into how customers, non-customers, neighboring businesses, and other stakeholders perceive the industry. In partnership with the City of Portland Bureau of Planning, UVG studied the economic and social implications of Portland's growing food cart industry, to determine if carts are a possible avenue for furthering these city objectives. The main goals of the project were to answer the following study questions:

- **Neighborhood Livability:** What effects do food carts have on street vitality and neighborhood life? What are the positive and negative impacts of food carts on the community?
- **Community Economic Development:** To what extent do food carts serve as an entry-point into long-term business ownership? Do carts provide beneficial economic opportunities for residents of Portland?

Based on this analysis, UVG made recommendations to promote the benefits of the industry and mitigate any negative impacts, particularly supporting the VisionPDX values.

Introduction

Study Questions

The study questions provided guidance for UVG to assemble relevant information through literature review, primary data collection, and stakeholder input. This information enabled UVG to develop findings that synthesized the results, highlight how food carts can benefit the community as well as identify challenges they may present. Contextualizing the study questions in academic literature and public policy goals elucidates how the methodologies were designed and the rationale that guided the determination of the study findings.

“Lowly, unpurposeful and random as they may appear, sidewalk contacts are the small change from which a city’s wealth of public life may grow”

– Jane Jacobs (1961)

“Vendors have become the caterers of the city’s outdoor life”

– William H. Whyte (1980)

Neighborhood Livability. Substantial research has demonstrated that urban design and surrounding land uses have a significant impact on the liveliness of streets and public interactions.⁴ A recent study on microscale physical characteristics of commercial streets found that personalization of storefront design increases pedestrian social behavior.⁵ Whyte (1980) referred to the “optical leverage” of food carts as spaces where people gather while waiting for food, which in turn attracts more people.⁶ Vacant lots and parking lots can create ‘gaps’ in the pedestrian environment, reducing ‘eyes on the street.’ This decreases safety or perceptions of safety, deterring people from walking in these areas. Interim uses of such vacant land can benefit the public while the market may not support additional investments.

According to an Oregonian article, a business owner near a new cluster of food carts on Hawthorne Blvd. acknowledged that the carts have increased his business due to the popularity of the carts.⁷

The City of Portland is currently involved in a long-range planning project, called the Portland Plan, in which staff will consider ways of using sidewalk space to benefit communities.⁸ The Plan will promote place-making, especially in neighborhood business districts, which can reinforce community identity and character, foster community connections, attract the creative class, and encourage knowledge workers, potentially leading to regional economic growth⁹. The Portland Plan’s Comprehensive Plan evaluation draft report considers compact, pedestrian-friendly corridors as crucial elements of fostering a livable community.

On the other hand, some storefront owners have expressed concern that food carts have an unfair advantage because of their reduced regulatory costs and lack of System Development Charges (SDCs).¹⁰ UVG conducted surveys and interviews of food cart customers and non-customers as well as neighboring business owners and inventoried the physical amenities of carts, to gain a more complete understanding of how food carts impact street vitality and contribute to neighborhood environments.



Image source: Willamette Week

Introduction

Community Economic Development. Community economic development can be defined as, “actions taken by an organization representing an urban neighborhood or rural community in order to

1. *Improve the economic situation of local residents (disposable income and assets) and local businesses (profitability and growth); and*
2. *Enhance the community’s quality of life as a whole (appearance, safety, networks, gathering places, and sense of positive momentum)*¹³

The City of Portland previously lacked information regarding the food cart industry, as carts are not included in the City’s annual business inventory because of their temporary and mobile nature. In other cities, several organizations have identified the food cart industry’s potential for supporting recent immigrants and low-income minorities – the New York City-based Street Vendor Project has a website with resources to aid vendors¹⁴ and a Roxbury, Massachusetts organization began the Village Pushcarts project to provide opportunities to residents without job skills or capital to start their own businesses.¹⁵ Recognizing the potential for the food cart sector to provide a viable means for low-income women to open their own businesses and support their families, Hacienda CDC is in its second year of offering a micro-enterprise food vendor program in Portland.

Food carts may fill a niche for workforce development strategies to offer equitable economic opportunities, which is a major aim of the Portland Plan. The technical working group has identified the need to “ensure economic opportunity is available to a diversifying population.”¹⁶ Finally, the economic report recommends fostering “a supportive climate for small and micro business development.”¹⁷

Micro-enterprise is typically defined as a business with five or fewer employees requires initial capital of less than \$35,000, and can be considered part of either formal or informal economy. Oregon is considered a small business state with more than 90 percent of all business enterprises employing 20 or fewer people¹¹. In Portland in 2002, of the 51,000 firms in the five-county area, nearly 39,000 had fewer than 10 employees providing more than 103,000 jobs¹². Food carts are one type of micro-enterprise business that may provide entrepreneurial opportunities for local residents, especially providing avenues for low-income and minority communities to raise their quality of life.

The Food Cart Industry in Portland and Elsewhere

While the presence of food carts has been receiving more attention recently, it is by no means a new phenomenon. Portland provided spaces for food carts as early as 1912, when Italian immigrant Joseph Gatto sold produce door-to-door from a horse-drawn cart in Sellwood and Northwest Portland. Even then, carts served as stepping-stones into storefront businesses. In the 1930’s he incorporated his cartbased business into a produce warehouse, and in 1935 the Southeast Portland-based Gatto & Sons wholesale produce company was born, and remains a successful business today.



*This horse-vending cart was parked at Southeast Clay and 7th Ave in 1929
Photo source: Oregon Historical Society*

Introduction

Currently, cities across the nation are using street vending as a way to provide diverse, affordable and quick food options. Municipalities can utilize food carts to accomplish city goals, and some have attempted to reduce conflicts by curtailing the presence of carts. Some recent street vendor policies include the following:

- In New York City, the Green Cart legislation allows new street vendors to acquire a license only if they sell fresh produce in low-income neighborhoods. This policy increases access to fresh food in neighborhoods with limited proximity to grocery stores.¹⁸
- In Toronto, a pilot project is looking into expanding street vending beyond the current limitation to hot dog vending. The City hopes to reflect its cultural diversity, build its image as a culinary destination, and increase access to a greater diversity of fast food options by encouraging vendors to sell pre-cooked pizza, samosas, burritos, and hamburgers. A university design competition created modern uniform street vending carts, which the city will rent to 15 vendors.¹⁹

- In downtown Seattle, street vending is currently limited to flowers, coffee, and hot dogs. The City is reevaluating its prohibition on street vendors selling food in downtown as part of their street activation program.²⁰

Several other cities are considering ways of substantially reducing the numbers of or eliminating food carts all together through regulation:

- In Los Angeles County, a regulation was recently passed that requires mobile eateries to move location every hour. The regulation was driven by brick-and-mortar restaurants in East L.A. who complained that taco trucks were negatively impacting their businesses. Remaining in the same place for more than an hour is now a criminal misdemeanor enforceable by \$1000 or six months in jail.²¹
- A similar regulation was passed in Hillsboro, Oregon in 2000 requiring taco trucks to move every two hours.²² This regulation severely limits the operation and profitability of carts.

When considering how to deal with the day-to-day management of food carts, jurisdictions can regulate them based on strictly-defined rules or more flexible standards. Areas of potential regulation can include the spatial location of food carts, placement and space allocation on a site, number of licenses available, types of goods that can be sold, and cart design.²³ While each jurisdiction handles street vending differently, the City of Portland's approach has encouraged the recent growth of carts on privately-owned commercial land, rather than on sidewalks. Because the Bureau of Development Services (BDS) and Multnomah County Health Department (MCHD) have minimal staff to regulate carts, issues about electricity or waste-water disposal are only addressed on a complaint-driven basis.



Introduction

Regulatory Issues

There are a number of common regulatory misunderstandings or concerns, which should be considered in the context of this study. UVG investigated the impacts of regulations to vendors and the public only insofar as they affect the study questions of neighborhood livability and community economic development. As it is beyond the scope of this study to comprehensively evaluate existing regulations, the impacts of the regulatory environment are discussed only when stakeholders addressed them in surveys or interviews. The following are a few existing regulations that help contextualize the project.

Food Safety. MCHD regulates food carts in the same way that all businesses that prepare and sell food products are regulated and all vendors must have a Food Handlers' license. MCHD is responsible for preventing food-borne disease and injury and for inspecting all restaurants, including food vendors, two times per year.

Push Carts vs. Stationary Mobile Carts. Push carts in the public right-of-way have different regulations than stationary mobile carts located on private property. The Portland Department of Transportation (PDOT) regulates temporary structures in the right-of-way, including push carts. While the City of Portland does not currently restrict the number of food carts in the region, PDOT strictly specifies how many push carts can locate on each block, the appropriate distance between carts, and minimum setbacks from the road and surrounding buildings. Push carts must also be approved through Design Review at the Bureau of Development Services.

As long as stationary mobile carts have functional wheels, an axle for towing, and are located in a commercial zone, they are considered vehicles and are not required to conform to the zoning or building code. They must have electrical or plumbing permits if sewer hook-ups or electricity are installed in the cart. If the wheels and/or axle are removed, the owner must obtain a building permit and conform to zoning code requirements and building inspections.

Despite the persistent misconception that food carts are under-regulated, the Multnomah County Health Department regulates carts in the same way that all businesses that prepare and sell food are regulated.

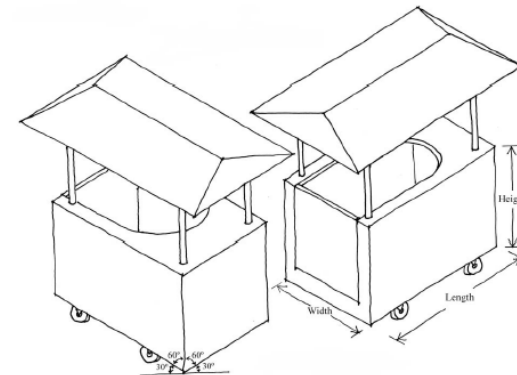

Pushcart vendors need to provide a sketch of their proposed carts to be considered for approval by the City.

Source: Portlandonline.com

Methodology

A variety of data collection techniques were developed to answer the study questions for the project. The City of Portland previously had little information regarding the food cart industry, as carts are not included in the City's annual business survey. The following definitions and methodologies were used to gain an industry-wide 'snapshot' of food carts in the City of Portland, and to conduct an in-depth comparison of a sample of four cart clusters.

Definition of Food Carts for the Study

Based on information from the organizations that regulate the food cart industry within the Portland metropolitan area, UVG defines food carts for the purpose of the Food Cartology project as follows:



Push Carts are small carts that are mobile and occupy a temporary location in the public right-of-way while they are operational



Stationary Mobile Carts have functional wheels and an axle, but occupy one, semi-permanent location.

Depending on the type of cart, different regulations apply, as outlined in the regulatory context section. This study surveyed push carts and stationary mobile carts, which have regular locations. Fixed carts without wheels and mobile carts that travel from site to site were excluded from this study, as they are subject to additional regulations and therefore have more barriers to market entry.

Literature Review

A review of existing literature helped indicate how food carts may contribute to creating neighborhood livability, to investigate available micro-enterprise opportunities, and to outline the possible ways a city can regulate the food cart industry. The literature review also guided the development of measurable indicators to create the survey instruments and interview questionnaires. In this way, the survey and interview questions were linked to concrete studies and theories, ensuring their capacity to address the study questions. This research also informed and framed the recommendations.

Technical Advisory Committee (TAC)

The Technical Advisory Committee (TAC) was comprised of professionals in the areas of economic development, urban design, livability, development regulation, micro-enterprise assistance, and others, in addition to food cart owners. The committee convened twice through the process; first to discuss the research questions and methodology, and second to review the findings and deliberate on the recommendations.

Methodology



Regulatory Session

UVG organized and facilitated a meeting with the City of Portland and Multnomah County Health Division employees who license, inspect, and regulate food carts. The meeting was an opportunity to gain insight into the issues and concerns of those who work with regulating food carts. A complete list of the attendees can be found in Appendix A.

All survey instruments can be found in Appendix B following.

Industry Overview

Mapping. UVG obtained a database of the Food Handlers' license inventory from MCHD for licensed "mobile units." The following carts were removed from the data set prior to mapping: inactive mobile units; mobile units noted as "not in operation during inspection;" and drive-thru coffee carts (determined using GoogleMaps viewer and on-site inspections). A number of the cart locations could not be geocoded due to incomplete address information. Of the 470 mobile units originally included in the database, 170 push carts and stationary mobile units remained. These carts were then mapped using Geographical Information System (GIS).

Vendor Survey. Vendors were asked about their motivations for opening a food cart business, difficulties they had experienced, and what assistance they may have received. The surveys were translated into Spanish, and UVG team members filled out surveys for vendors who required assistance with English.

With a population of 170 carts, team members attempted to survey 97 carts altogether. Of these, 38 were not open, not at their specified location, or were determined

to not fit the definition of food carts outlined above. Another five vendors declined participation. In total, 54 surveys were completed.

Site and Cart Inventories. UVG inventoried the physical characteristics of the four study sites, including publicly-provided amenities. Carts were surveyed for physical condition such as the exterior of the cart, awnings, signage, and privately-provided amenities, such as trees, benches, and trash cans. Both study sites and additional carts were inventoried.

Online Survey. An online survey gathered perceptions of food carts from the general population. It was hosted on the website www.foodcartsportland.com and was linked from www.portlandfoodanddrink.com. Many of the questions were similar to the public intercept survey, but focused more generally on the cart industry. 474 people responded to this survey, 450 of whom responded that they eat at food carts, and 24 of whom do not consider themselves food cart consumers. Because this sample contains strong food-cart biases and is restricted to online responses, these results were not combined with those from the public intercept survey.

Methodology

Site Analyses

After consulting with the Bureau of Planning and the TAC, UVG selected four study sites that represent the diversity of the neighborhoods where food carts are currently located, as well as differing typologies of cart clusters.

Table 1: Characteristics of Selected Cart Sites

Site	Typology	# of Carts
Downtown 5th & Oak	Dense cluster in central business district	20
Mississippi	Corridor along neighborhood commercial street	4
Sellwood	Smaller cluster on one site	3
Cully	Scattered carts within walking distance	3

At each of the study sites, UVG conducted vendor surveys, neighborhood business surveys, public intercept surveys, and site and cart inventories, as well as conducting interviews with individuals from

each of these groups. GIS was used to map area demographics and surrounding land uses. The following methods were additionally used to gather data at each study site:

Public Intercept Surveys. Approximately 30 pedestrians near each of the four study sites were surveyed to assess perceptions about the impacts the carts have in the neighborhood. In order to survey both customers and non-customers, half of these surveys were gathered near the cart location, while the other half were administered off-site, usually near an alternative eating establishment. Additionally, random intercept surveys were conducted at Lloyd Center and Pioneer square. When the results refer to the public “overall,” the statistics are referring to all sites as well as these two additional locations.

Neighborhood Business Survey. UVG attempted to survey the manager or owner of every storefront retail business located on blocks adjacent to the food cart study site. This survey gauged attitudes toward and perceptions of the food carts’ effects on businesses in the neighborhood.

Table 2: Survey Response Rates

	Downtown		Mississippi		Sellwood		Cully		Overall	
	Delivered	Completed	Delivered	Completed	Delivered	Completed	Delivered	Completed	Delivered	Completed
Vendors	19	14	2	3	3	3	5	4	126	78
Neighborhood Business	27	21	17	9	23	14	21	16	85	63
Public Intercept	-	44	-	32	-	27	-	23	-	215

Note: The overall public intercept surveys include the 89 surveys collected at Pioneer Square and Lloyd Center

Methodology

Interviews

Interviews were designed to supplement the surveys by providing insight into the perspectives, opinions, and interests of stakeholders, especially those who do not fit into easily-defined survey populations. Allowing individuals to speak in a personal and in-depth manner also revealed different insights and provided a more personal perspective. Interviews were conducted in person or by phone, and notes were input into a spreadsheet and analyzed to identify recurring themes. The information derived from the interviews helped shape the findings and recommendations, particularly when survey information was unavailable or insufficient. A complete list of interviewees can be found in Appendix C.



Cost of Doing Business Comparison

Using data and information provided by Mercy Corps Northwest, the Bureau of Planning, Portland Development Commission, as well as results from interviews and vendor surveys, UVG developed a list of traditional line items that new business start-ups can anticipate as typical baseline costs, depending on if the business is based in a push cart, a stationary mobile cart, or a storefront restaurant. This information informs the community economic development findings and indicates the financial differences between operating a food cart and small scale storefront start-ups.

Study Limitations

Despite UVG's best efforts, this study contains some limitations, especially in the data collection process. The majority of food cart vendors were willing to complete surveys; however, there were specific questions regarding gross profits, employee data, and other information that vendors either may have misinterpreted or were unwilling to share. The interviews gathered some of this information by building more trust, but the sample size was quite small. Additionally, the public intercept surveys were likely biased, as most of the people willing to complete the survey were interested in food carts. Finally, the sample sizes are small and provide a snap-shot analysis of food carts and public perceptions, rather than being statistically significant.

Site Analysis

Location of push carts and stationary mobile carts in Portland.

Data source:
Multnomah County
Health Department

170 Food carts
24 Nationalities
64% Of customers
want recyclable to-go
containers
\$1- Typical recent
increase in a lunch
special due to the
increased cost of
grain

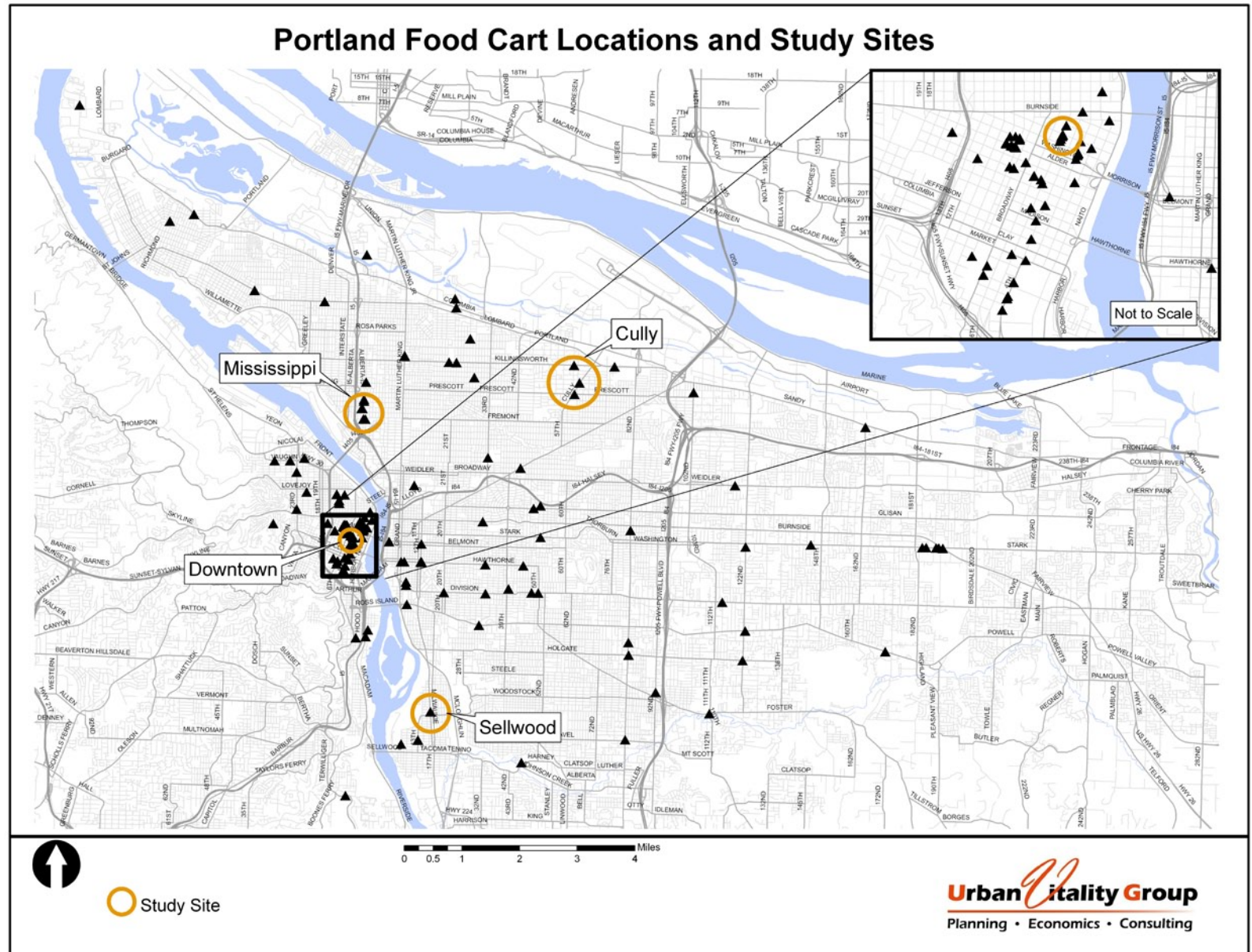

Site Analysis-Downtown



Neighborhood Context:

The first of Portland's food cart clusters, these carts are an epicenter of pedestrian activity in the area. The food carts in downtown Portland are quite popular, and it is common to see lines of ten or more people at a cart waiting for lunch. The downtown area has a significant residential population and a high employment density, especially near the study site cluster at 5th and Oak. The area is also undergoing significant changes. A new park is under construction, multiple buildings are currently being renovated or built, and a \$200 million transit mall improvement project is underway.

Food carts on site since: Approximately 2000

Current Number of Carts on site: 20

Owner: City Center Parking, The Goodman Family

Site Future: There are no current plans to develop the site, although it is along the future transit mall and pedestrian safety concerns may be addressed.

Lease Terms: \$550/month includes electricity, fresh water, security, and pest control. Carts are responsible for waste water removal and trash disposal

Site Improvements: ATM on site. The renovation of the transit mall includes plans to install several decorative glass and metal panels along the outside border of the sidewalk at this site.

Downtown (5th and Oak)

Population	10,070	Crimes per 1000 people ²⁴	282
People in Poverty	31%	Percent population within ½ mile of grocery store ²⁵	76%
People of Color	26%		
Employees in Market Area ²⁶	31,071	Upper Income Households (\$125k+)	4%

Site Analysis-Downtown



Ana Maria
Loco Locos Burritos

Locos Locos Burritos began operating at the parking lot on SW 5th Avenue seven years ago. After working in the service industry for several years, Ana Maria and her boyfriend decided to open a food cart. The food cart would combine two of their existing talents since her boyfriend likes to cook and Ana Maria is “very good with people.” They saved money to purchase a cart without loans or other financial assistance and renovated the kitchen for full-time use.

After five years of hard work and saving they were able to expand and open a second Loco Locos Burritos location at SW 9th and Alder Street, also located downtown. The second location has also been very successful. When asked how they measure the success of their business, Ana Maria responded that independence and the ability to spend time with her family are important to her. They are currently in the process of expanding their business into a storefront near Portland State University campus, while continuing to operate their two existing carts. Ana Maria was the only food cart owner that was identified through the research with immediate plans to expand into a storefront.

Key Findings:

- **Limited shelter and seating:** customers responded most frequently that food carts in the downtown site could be improved by providing shelter (42%). The only sheltered eating area at the downtown site is at the New Taste of India cart. The cluster had the fewest average seats per cart with only .5 per cart compared to an average of 5 seats per cart overall.
- **Customers want the carts to stay open late:** the other most-often cited improvement was for the carts to operate evening hours (42%).
- **Downtown is the least social site of those surveyed:** only 39% of customers surveyed at the downtown site indicated that they agree or strongly agree with the statement: *I have conversations with other customers at food carts*, compared to 51% overall.
- **Downtown carts increase foot traffic:** 58% of businesses strongly agreed or agreed with the statement: *The presence of food carts has increased foot traffic on the street.*
- **Carts are more profitable downtown than ones located outside the CBD:** 92% of downtown vendors strongly agree or agree that the cart has been a good way to support themselves and their families, and 60% report being able to save money for a rainy day.
- **Downtown carts are more stable:** on average, carts downtown have been in operation since 2003, compared to 2006 for the overall population. Downtown carts may be less likely to move into a storefront: only 42% plan to move into a storefront in the future, compared with 51% in the overall population, and much higher percentages at the other study sites.

“Food carts are a Petri dish for the organic growth of restaurants.”

-Mark Goodman, property owner of food cart site

Site Analysis-Mississippi



Neighborhood Context:

Mississippi Street is a harbor for hip restaurants, boutiques and most recently condos and apartments under rapid-fire construction. Long the home of Portland's African-American community, Boise is now experiencing significant demographic shifts. The previously low-income neighborhood is now seeing home values rise and incumbent residents are faced with steeper rents, the specter of displacement and commercial changes catering to higher income levels.

Food carts first located on site: 2004, 2007

Current Number of Carts on site: 3 (on separate lots)

Owner: Multiple property owners associated with food cart locations.

Site Future: Two of the sites are slated for redevelopment in the near future. One cart is considering moving into the storefront, while the other is looking for a new site.

Lease Terms: Annual lease, \$300/month, access to fresh water, electricity, and waste water disposal.

Site Improvements: varies

Boise Neighborhood

Population	3,090	Crimes per 1000 people	119
People in Poverty	30%	Percent population within ½ mile of grocery store	0%
People of Color	67%		
Employees in Market Area	1,855	Upper Income Households (\$125k+)	1%



Judith Stokes
Tita's Pista

Judy entered the food cart business partly because of her mother. "She is from the Philippines and I learned how to cook from her. I want to share the food from my mother's home country with the community."

It was hard for Judy to find a location for her cart. Mississippi is a rapidly developing area, and many property owners are expecting to develop their properties. "A lot of people turned me down. Mississippi is developing so fast and many property owners are selling their property. When I asked them to lease me their land for a few hundred dollars a month, they were laughing at me." Even the current location is not stable: the landlord is going to develop the site and Judy will have to move to another location, which will cost her more than \$2,000.

Site Analysis-Mississippi

Key findings:

- **The top concern of Mississippi customers was for the carts to stay open in the evening:** 54% of customers would like the carts to stay open later.
- **Mississippi carts are the most appealing:** 80% of those surveyed found the cart exteriors appealing compared to 52% overall.
- **Surrounding businesses support the food carts:** 81% of surrounding businesses surveyed in Mississippi indicate that they have a very positive or positive perception of the food carts compared to 66% overall.
- **Cart operators have a strong relationship with their customers:** 82% of customers stated that they strongly agree or agree with the statement, *I have conversations with the operator other than ordering food, compared to 66% overall.*
- **Customers at the Mississippi carts eat there infrequently:** 59% of customers indicated that they eat at food carts less than once a week compared to 38% overall.
- **The Mississippi site is very social:** 71% of customers in Mississippi, indicate that they agree or strongly agree with the statement: *I have conversations with other customers at food carts, compared to 55% overall.* Sixty-three percent of customers in Mississippi indicate that they agree or strongly agree with the statement: *I have met new people while patronizing food carts, compared to 40% overall.*
- **The Mississippi site had the most seating** with an average of 11 per cart compared to an overall average of 5 per cart.
- **Mississippi carts are a good place to people-watch:** 46% of customers at the Mississippi site did indicate that they go to food carts to people watch compared to only 14% overall.
- **There is a different demographic mix than downtown:** there are no taquerias along the Mississippi corridor, and all of the vendors were born in the U.S.
- **Cart owners have good relationships with their landlords:** all three cart vendors strongly agreed that they have friendly relationships with their landlords.

Site Analysis-Sellwood



Neighborhood Context

The Sellwood neighborhood is a destination for antique collectors with dozens of antique shops in Victorian homes and renovated storefronts that line SE 13th Ave. Considered by many to be one of Portland's most family-friendly neighborhoods, Sellwood-Moreland has the lowest crime rate and lowest poverty rate of the four study sites.

Food carts first located on site: 2007

Current Number of Carts on site: 4

Owner: Mark Gearhart (Also owns adjacent antique store)

Site Future: In the immediate future the site will remain a food cart court, but it is for sale for the right price. Farmers' market vendors can also rent space

Lease Terms: Annual lease, \$449/month plus \$50 for electricity and a \$500 one time hook-up fee.

Site Improvements: Gravel and bark surface provided, electrical hookups, waste water disposal, storage sheds for rent, picnic tables, trash dumpsters for food carts.

Sellwood-Moreland Neighborhood Demographics

Population	10,590	Crimes per 1000 people	55
People in Poverty	9%	Percent population within ½ mile of grocery store	74%
People of Color	11%		
Employees in Market Area	2,983	Upper Income Households (\$125k+)	5%

Site Analysis-Sellwood



Mark Gearhart
Property Owner
Sellwood Site

Mark Gearhart, owner of the Sellwood Antique Mall for 19 years, decided to do something with the adjacent empty gravel lot. Unable to turn it into a parking lot due to the cost of complying with storm water regulations, he decided to create Sellwood's very own food cart court. He laid down gravel and bark and installed electrical, fresh water, and wastewater hook ups. He offers the carts one-year leases and has built storage facilities so the carts can store their food on-site. He provides picnic tables, trash, and recycling facilities. He spent over \$7,000 improving the site. While Mark admits his lot will not remain a food cart site forever, in the interim he will increase his cash flow and earn back the investment he made to the property. Mark has created a model for creating an intentional, well-maintained lot, and he strongly feels that food carts should not be more heavily regulated. He also owns a lot at SE 33rd and Hawthorne, where he would like to create another food cart plaza.

Key findings:

- **Recycling is important to Sellwood customers:** according to the customers surveyed, the most important improvement that food carts could make was to use recyclable containers (42% of customers said that this was important).
- **Customers have strong relationship with the food cart vendors:** 89% of customers surveyed in Sellwood stated that they strongly agree or agree with the statement: *I have conversations with the operator other than ordering food*, compared to 66% overall.
- **Customers eat infrequently at food carts:** in Sellwood, 89% of customers eat at food carts less than once a week compared to 38% overall.
- **The Sellwood site is visually appealing:** according to the public surveys, the Sellwood site was the second most appealing of all the sites studied.
- **Outdoor seating is important to Sellwood customers:** 43% of customers report eating at the Sellwood carts because of the availability of outdoor seating.
- **Vendors at the Sellwood site consider the cart a stepping-stone:** two of the three carts surveyed report planning to move into a storefront, while the last cart is operated by a retiree who has been traveling with his cart for years.

"Food Carts add an element of controlled chaos and break the monotony of the built environment."

-Mark Gearhart, property owner

Site Analysis-Cully

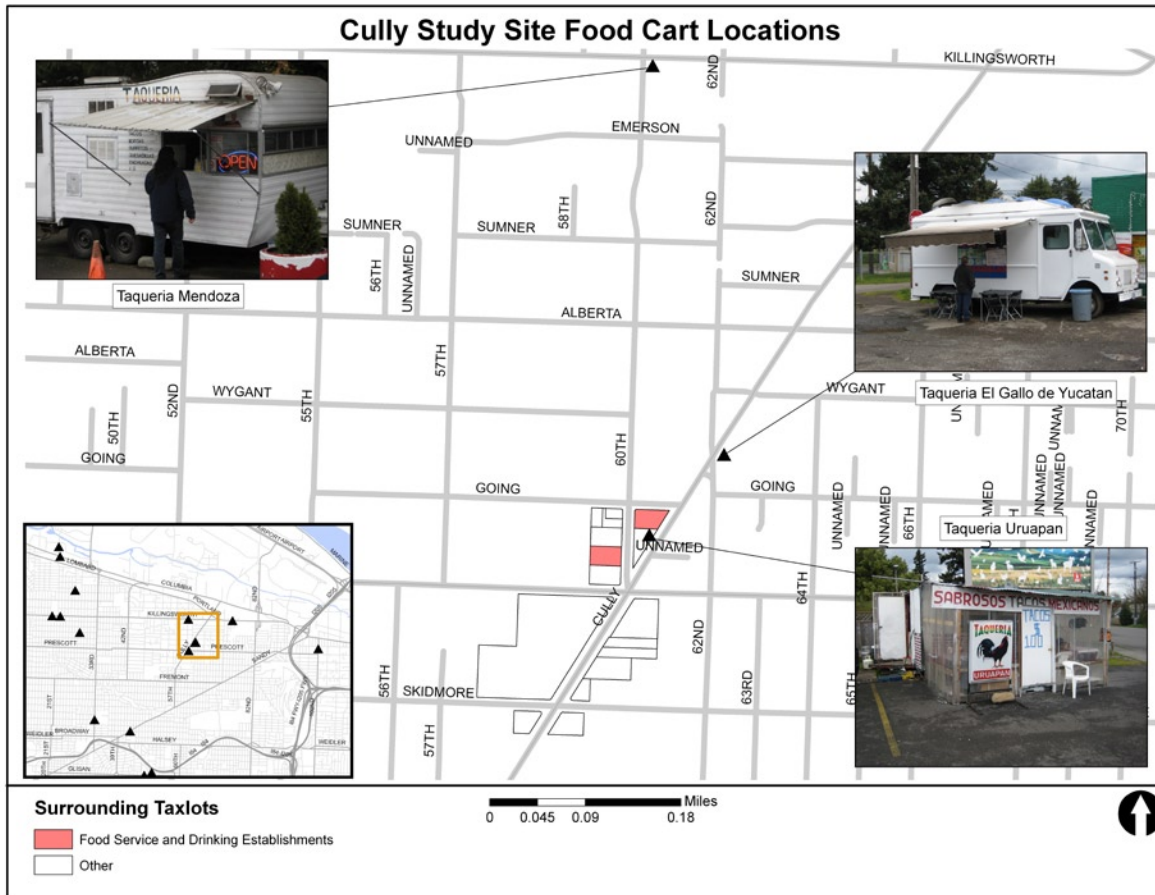

Neighborhood Context:

Cully is one of the most diverse neighborhoods in Portland, with people of color comprising nearly half of Cully's population. The presence of Latino culture is evident by the several "mercados" and food carts that dot the area. The lack of sidewalks along Cully Boulevard poses a significant challenge to the area's walkability. There is a dangerous five-street intersection that is a significant barrier and is difficult to cross. Local independent businesses, including food carts, are an important part of the mix of land uses that offers Cully residents places to gather and meet their food needs locally.

Food carts first located on site: Approximately 2002

Current Number of Carts on site: 3 (on separate lots)

Owner: Gerald Kieffer

Site Future: Mr. Kieffer's plan is to establish four "trolley car carts" on the site and establish a food cart court. Additionally, a Cully Green Street Plan is currently in its initial phase and will likely result in improved pedestrian safety.

Lease Terms: Month-to-Month. \$550/month, water is included. Vendors pay separately for electricity, and take care of their own waste water removal and trash disposal.

Site Improvements: Currently a paved parking lot with limited site improvements. Taqueria Uruapan provides a small sheltered and heated dining space.

Cully Neighborhood

Population	13,000	Crimes per 1000 people	67
People in Poverty	18%	Percent population within ½ mile of grocery store ²⁷	24%
Latino Population	20%		
Employees in Market Area	4,401	Upper Income Households (\$125k+)	2%

Site Analysis-Cully



Bartolo and Araceli
Taquería Uruapan

Taquería Uruapan is truly a family-run business. Bartolo and his wife Araceli run their food cart with dedication. Operating their cart more than 12 hours a day, the couple has turned it into a tiny dining area protected from the elements that creates a friendly atmosphere for sharing food and conversation. The couple moved to Oregon from California after taco carts were banned in their city. They originally migrated from Mexico and took over the food cart operation from Araceli's brother who had started it five years earlier. They have been held-up three times in the past eight months, and the crime in the area creates an on-going issue.

The family struggles to make ends meet, making just enough money to pay their bills. During winter months when business is slow, they rely on the small savings they had before moving to Oregon to survive. Their future as cart vendors is also uncertain: the current site is temporary, and the property owner has no long-term intentions of allowing food carts. They continue to rent the cart from Araceli's brother, but hope to save enough money to someday buy their own cart and have a self-sufficient business.

Key findings:

- **The Cully site was the least visually appealing of all sites:** only 30% of those surveyed found the exterior of the carts appealing compared to 52% overall.
- **Food cart customers do not walk to the Cully site:** only 25% of food cart customers indicated that they walk to the carts in Cully.
- **The Cully site is very social:** 63% of respondents in Cully agree or strongly agree with the statement: *I have conversations with other customers at food carts* compared to 51% overall. Another 63% of respondents agree or strongly agree with the statement: *I have become better acquainted with people while patronizing food carts* compared to 42% overall. Eighty-one percent of customers surveyed either strongly agreed or agreed with the statement: *I have a good relationship with one or more food cart operator* compared to 51% overall.
- **The relationship with the Cully carts and surrounding businesses seems strained:** only 43% of businesses surveyed have a very positive or positive perception of food carts compared to 66% overall. Three-quarters of business owners stated that their employees never eat at food carts. None of the businesses agreed or strongly agreed with the statement: *I have a good relationship with the food cart operators*, compared to 55% of businesses at all the sites.

Food carts bring value to surrounding properties. They provide a service and employment. As long as it is done right and run nice.

-Gerald Kieffer, property owner

Findings

“Food Carts bring more people to an area and create a neutral space where people can gather on the street and socialize.”
—Paul Basset, Avalon Vintage



Based on the results of the surveys, inventories, and interviews, both for the four study sites and the overall population, UVG assembled the following key findings that answer the study questions. Following the summary of the findings is a discussion of the data results that provide support for these statements.

1. Food carts have positive impacts on street vitality and neighborhood life in lower density residential neighborhoods as well as in the high density downtown area.
2. When a cluster of carts is located on a private site, the heightened intensity of use can negatively impact the surrounding community, primarily from the lack of trash cans.
3. A cart's exterior appearance does not affect social interactions or the public's overall opinion of the carts; seating availability is more important for promoting social interaction than the appearance of the cart's exterior.
4. The presence of food carts on a site does not appear to hinder its development.
5. Food carts represent beneficial employment opportunities because they provide an improved quality of life and promote social interactions between owners and customers.
6. Despite the beneficial opportunities that food carts can provide, there are numerous challenges to owning a food cart.
7. While many food cart owners want to open storefront businesses, there is a considerable financial leap from a food cart operation to opening a storefront.
8. Food cart owners do not frequently access small business development resources available to them, such as bank loans and other forms of assistance.

Neighborhood Livability



The study questions relating to street vitality and neighborhood livability were:
What effects do food carts have on street vitality and neighborhood life?
What are the positive and negative impacts of food carts on the community?

1. Food carts have positive impacts on street vitality and neighborhood life in lower density residential neighborhoods as well as in the high density downtown area.

They provide affordable and convenient food options, create opportunity for social interaction, improve public safety by increasing 'eyes on the street,' and help to facilitate a pedestrian-friendly urban environment.

Pedestrian Access

- **Most customers walk to food cart sites:** 65% of customers indicated that they walk to food carts. 62% of all sites have a crosswalk to the site.
- **Sites tend to have good pedestrian access:** 76% of sites are located on streets where the speed limit is less than 30 MPH. Only 9% of respondents in the public survey indicated that pedestrian sidewalk clearance is a concern.
- **Cart customers may impede sidewalks:** two Portland urban designers interviewed cautioned about the importance that customer lines not block pedestrian flow or obscure storefront businesses.

Perceptions of Safety

- **There are mixed opinions about whether the presence of food carts makes the site safer:** 59% of respondents to the public survey either strongly agreed or agreed with the statement: *The presence of food carts makes the street feel safer* – compared to only 28% of businesses. However, the majority of the five business owners who were interviewed indicated that the presence of food carts makes the area safer.

Findings

Neighborhood Livability

Venues for Informal Social Interaction

- **Customers have informal conversations at carts:** half of customers surveyed agreed or strongly agreed with the statement: *I have conversations with other customers at food carts.*
- **Customers and vendors tend to have good relationships:** 66% of customers surveyed strongly agreed or agreed with the statement: *I have conversations with the operator other than ordering food.* Half of customers surveyed either strongly agreed or agreed with the statement: *I have a good relationship with one or more food cart operators.*

Public Perceptions of Carts

- **Overall perceptions of carts are positive:** 94% of food cart customers surveyed indicated that they have a very positive or positive perception of food carts. 44% of non-customers surveyed also indicated that they have a very positive or positive perception of food carts.
- **Both customers and non-customers say that food carts are a better use of a vacant lot than parking:** 81% of food cart customers and 42% of non-customers either strongly agree or agree with the statement: Food carts are a better use of a site than a parking lot.

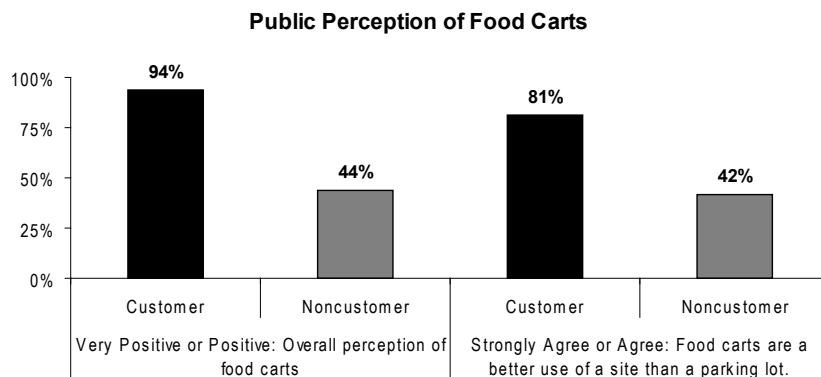

The smell of the food is out in the street; the place can be surrounded with covered seats, sitting walls, places to lean and sip coffee, part of the larger scene, not sealed away in plate glass structure, surrounded by cars. The more they smell the better.

- A Pattern Language

Neighborhood Livability

Neighboring Business Perceptions of Carts

- **Managers or owners of surrounding businesses have a positive overall perception of food carts:** Overall, 66% of surrounding businesses surveyed reported a positive or very positive perception of food carts.
- **While owners and managers of restaurants are less likely than other businesses to have a positive impression of food carts in their neighborhood, the majority of them are positive:** 69% of restaurants and 94% of other businesses ranked their overall impression of food carts positive or very positive.
- **Business would prefer parking over food carts:** only 35% of businesses surveyed either strongly agree or agree with the statement: *Food carts are a better use of a site than a parking lot.*
- **Restaurants are less likely than other kinds of businesses to want more food carts in their neighborhoods:** 25% compared to 55% agreed or strongly agreed with the statement, *I would like to see more food carts in my neighborhood.* In fact, only 35% of businesses surveyed either agree or strongly agree with the statement: *Food carts are a better use of a site than a parking lot.*
- **Most neighboring businesses did not perceive an impact of the food carts on their businesses:** of the businesses surveyed, only 8% either strongly agreed or agreed with the statement: *my sales have increased because of the presence of food carts.* Only 40% of businesses surveyed either strongly agreed or agreed with the statement: *the presence of food carts has increased foot traffic on the streets.* However, at the downtown site 58% of business agreed or strongly agreed with that statement.

Surrounding Business Perception of Food Carts

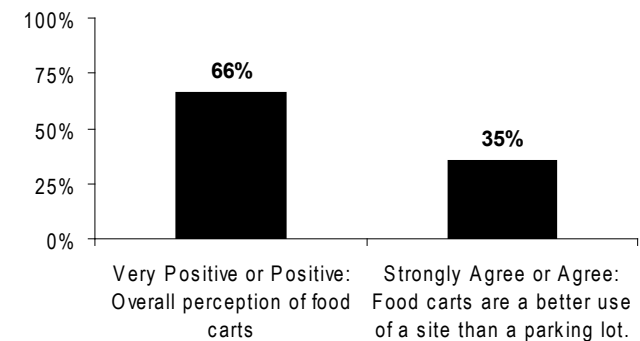

“Overall, I support food carts, if the product is good, they encourage foot traffic.” –Neighboring Business Owner

“Food Carts bring more people to an area and create a neutral space where people can gather on the street and socialize.” – Neighboring Business Owner

“Our business does not compete with food carts. We are a fine dining restaurant. We share customers but they are looking for a different experience at different times.” – Neighboring Restaurant Owner

Findings

Neighborhood Livability

2. When a cluster of carts is located on a private site, the heightened intensity of use can negatively impact the surrounding community, primarily from the lack of trash cans.

Amenities

- **Sites frequently lack publicly-provided amenities:** 86% of cart sites had no publicly provided benches, and 38% of cart sites had no street trees.
- **Food cart owners often provide street amenities including seating, trash cans, and occasionally landscaping:** 73% of cart sites had at least some sun-protected seating area, provided by trees, awnings, or umbrellas. On average, a food cart provides 5 seats. In downtown, the average was 0.5 seats per cart.
- **The majority of cart sites do not have trash cans:** 66% of cart sites had no publicly provided trash cans nearby, and 45% of food carts do not individually provide trash cans for their customers. According to the interviews, there is no incentive to put out a trash can if the neighboring cart is not required to do so.

3. The exterior appearance of a cart does not affect social interactions or the public's overall opinion of the carts; seating availability is more important for promoting social interaction than the appearance of the cart's exterior.

Cart Aesthetic Appearance

- **Overall, people view food carts as aesthetically pleasing:** over half of respondents to the public survey indicated that the cart exterior was visually appealing.

- **Opinions about aesthetics vary between the sites:** the most public intercept respondents found carts at the Mississippi site appealing, followed by Sellwood, Downtown and were least likely to find carts in Cully appealing.
- **The carts are generally in good repair:** the cart inventory found that only 11% of food cart were visibly in disrepair.
- **There is a noticeable smell from food carts, but most people find the smell pleasant:** 65% of respondents in the public survey stated that there is a noticeable smell from food carts and 86% say the smell is pleasant.
- **Food cart sites are not noisy:** 90% of respondents in the public survey and 74% in the business survey indicated that there was no noticeable noise from food carts.

Percent of Public Survey Respondents Who Find the Exterior of Food Carts Appealing by Site

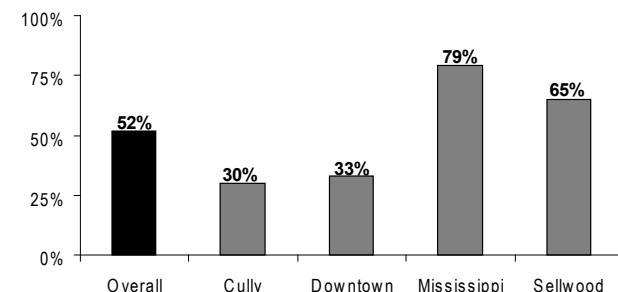

Neighborhood Livability

Variations in Social Interactions

- **There is not a strong relationship between public perceptions of cart appearance and reporting on social interactions:** for example, while only 30% of public respondents at the Cully site found the exterior of the carts appealing, 63% strongly agreed or agreed with the statement: *I have conversations with other customers at the food carts.*
- **Carts with seating availability are more likely to foster social interaction:** at the downtown site, which has an average of less than one seat per cart, only 40% of customers strongly agreed or agreed with the statement: *I have conversations with other customers at the food carts.* At the Mississippi site, which averaged 13 seats per cart, 71% strongly agreed or agreed with the statement.

4. The presence of food carts on a site does not appear to hinder its development.

Although many factors influence how and when a property is developed, property owners interviewed did not feel that the presence of food carts would prevent them from developing the site. Interim uses for parking lots, such as food carts, can be an additional source of income for property owners, facilitate opportunities for social interaction, and increase street activity.

Influences on Permanent Site Development

- **Property owners intend to develop food cart sites when the market is ready:** all four property owners indicated that they would develop the property when the market conditions were right. Two sites at Mississippi have immediate plans for redevelopment.
- **Food carts do not tend to locate in areas with many vacant storefronts:** three of the study sites had one or fewer vacant storefronts.

Online survey Results

To gain a broader perspective of public perceptions of food carts, UVG posted an online public survey, which received 474 completed surveys. Ninety-five percent of respondents were food cart customers, compared to 69% of the public surveyed on the streets. In addition, the population of people who respond to online surveys tend to be self-selected and a different demographic – UVG’s online survey respondents had higher incomes than those randomly intercepted on the street: 40% had a household income of \$75,000 and above, compared to 14% of public intercept respondents. Due to these differences, the results of this survey have been considered separately from the public intercept surveys, and are not part of the “overall” statistics given. The differences between surveys may indicate the extent to which people who eat at carts regularly care about the food carts in Portland.

Highlights of the Online Survey:

- 42% of customers eat at food carts 1-2 times per week and 40% eat at carts 3-4 times per week.
- 78% of respondents cited affordability as a reason they patronize food carts.
- 17% of customers said they would eat at food carts if the cart transitioned to a storefront business and the prices were higher.
- Of those who don’t eat at food carts the top concerns were:
 - Concerns with unsafe food handling (63%)
 - Lack of shelter from weather (47%)
 - Unappealing condition of cart (46%)
 - Nowhere to sit (33%)
- The top four ways that food cart customers thought food carts could improve:
 - Provide recyclable containers (64%)
 - Install additional shelter (51%)
 - Open evening hours (46%)
 - Provide seating (35%)
- 82% of customers get their food to go.

Findings

Community Economic Development



The study questions that address community economic development potential were:
To what extent do food carts serve as an entry-point into long-term business ownership?
Do carts provide beneficial economic opportunities for residents of Portland?

5. Food carts represent beneficial employment opportunities because they provide an improved quality of life and promote social interactions between owners and customers.

Food cart owners indicated that independence, flexibility of schedule, and opportunity for family involvement are important to their quality of life. Food carts provide their owners and operators an opportunity to interact with customers in more candid way than storefront restaurants.

Characteristics of Vendors

- **Owners of food carts are often minorities and immigrants:** over half of the food cart vendors surveyed outside the CBD are Hispanic, whereas there is a greater mix of ethnicities (Hispanic, Caucasian, and Asian) within the CBD. In addition, more than half (51%) of the vendors surveyed were born outside of the US.

Financial Success

- **Food cart vendors can mostly support themselves and their families:** 63% of vendors agreed or strongly agreed with the statement: *The food cart has been a good way for me to support myself and my family.*
- **Approximately half of vendors own a home:** 49% of the vendors report owning their own home.
- **Several cart owners have other jobs:** 19% of respondents reported having an additional year-round job and another 13% have seasonal jobs in addition to the cart.
- **Push carts and food carts offer a range of start-up costs that require incrementally smaller investments than a small business:** the start-up costs for a small business with one employee is approximately 50% more than those of a high-end food cart (see Table 3).

Community Economic Development

Measures of Success

- **Many vendors enter the food cart business (rather than another industry) because of a desire for independence, flexibility, and as a stepping-stone for opening their own restaurants:** across the city, vendors most frequently cite a desire for independence as important for entering the cart industry (68%). After independence, a desire to have one's own restaurant, wanting to be a cook, and a desire for flexibility were all frequently cited goals (46%, 23% and 20% overall, respectively).
- **The majority of cart owners value getting by independently over profits:** 47% of vendors answered "able to get by independently" when asked how they would measure if their business is successful, whereas only 26% answered "profits." Forty-seven percent also answered "many customers." Other measures of success included using local produce for a majority of food, being happy on a deep and interpersonal level, and making people happy.
- **Food cart vendors often value their relationships with customers and ability to interact more directly than if they were in a storefront:** according to the interviews, vendors reported enjoying interacting with customers and communities in a way they may not be able to as cooks in a restaurant.
- **Food carts are often a family business:** several interviewees felt that family nature of the business was a benefit to them.



Introduction



Methodology



Site Analysis



Recommendations

Findings

Community Economic Development

6. Despite the beneficial opportunities that food carts can provide, there are numerous challenges to owning a food cart.

Some of the most frequently-cited challenges include: finding a stable business location, saving money, and realizing long-term business goals.

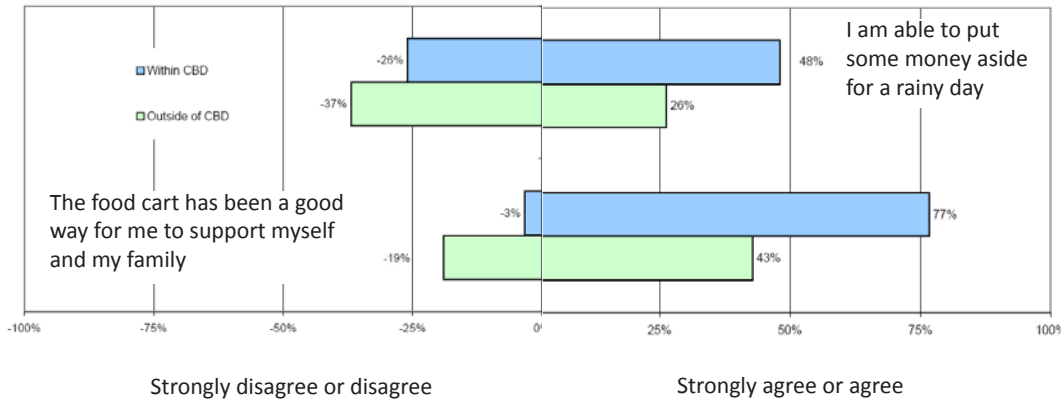

Ability to Save Money

- Few cart owners are able to save money for a rainy day: Only 40% agreed or strongly agreed with the statement: *I am able to put some money aside for a rainy day*, whereas 31% disagreed or strongly disagreed with the statement

Locational Differences in Profitability

- Food carts within the CBD are more profitable than those outside of the CBD:** vendors operating within the CBD were more likely than those operating outside to agree or strongly agree that the food cart has been a good way for them to support themselves and their families (77% compared to 43%). Of the vendors operating within the CBD, 48% reported being able to save money, whereas of those outside the CBD, only 26% agreed or strongly agreed.
- Finding a site is a challenge:** 52% of cart owners responded that finding a site for their cart was a challenge to begin their businesses.



Photo: foodcartsporeland.com

Community Economic Development

7. While many food cart owners want to open storefront businesses, there is a financial leap from a food cart operation to opening a storefront.

Additionally, since the size and scale of food cart operations are limited by the physical structure, it is difficult to find a storefront of the appropriate size at the necessary time to incrementally grow a cart-based business. Current codes encourage retail spaces designed to attract specific types of businesses, particularly by conforming to size requirements for chain retail establishments.

Desire to Move into a Storefront

- **Food carts vendors sometimes consider the cart to be a stepping-stone to a storefront business:** over half (51%) of food cart vendors surveyed plan to move into a storefront in the future; there is not a large difference between vendors operating within the CBD (47%) and those outside of it (55%).
- **Vendors who want to open a storefront often do not plan to sell their cart:** several of the vendors interviewed plan to keep their carts if they move to a storefront, either as an additional location or to enhance their storefront location.
- **Some vendors are not interested in expanding, often because of perceived difficulties these including financial difficulties and finding a location.:** several vendors said they were not interested in moving into a storefront. One cart owner was concerned about losing the intimate customer interaction she currently has at her cart.

Difficulty of Moving into a Storefront

- **The largest perceived barrier to expansion or relocation was financial:** 50% of people thought they might be prevented from expanding or relocating because of lack of money, whereas only 17% thought city regulations would be a barrier. Several people also wrote-in concerns about finding the right employees for a larger space.
- **There are only a few examples of businesses that began as carts moving into storefronts successfully:** while several owners reported planning to move to a storefront, only a few cart owners are currently in the process of moving, and fewer have moved successfully.
- **Because the total costs for operating a food cart (or push cart) are substantially less than those of a storefront restaurant, it is quite difficult to make the transition into a storefront:** while the significant difference in costs for a food cart and a storefront is a benefit for market-entry, it is a barrier to growing the business (see Table 3 in page35). Even the most successful food carts, who have the means and business capabilities of making the transition, are limited to specific conditions that will allow for continued success in a storefront, such as finances, timing, and space.

“I like being outside. I see a million faces everyday. Working a kitchen, it is too crowded and sucks your soul.” – Food Cart Owner

“I feel good about what I am doing and making people happy.” – Food Cart Owner

Findings

Community Economic Development

8. Food cart owners do not frequently access small business development resources available to them, such as bank loans and other forms of assistance.

The majority of food cart owners do not have business loans through banks or other lending groups, but they do have access to funds through personal means that allow them to start their businesses without institutional debt. The under-utilization of these resources may contribute to difficulties associated with opening and operating a food cart.

Accessing Assistance

- **Few vendors receive job training, help developing a business plan, or financial assistance aside from their family and friends:** only 18% of vendors overall received any initial job training, such as what Mercy Corps NW offers.
- **Most cart owners financed their business with help from family or by using their savings:** over half of vendors (51%) report receiving assistance from family members, and almost half used personal savings (49%) to start their businesses. Only 2% received support from an organization, and 8% used a home equity loan. One vendor interviewed said he talked to his bank about getting a loan, but he thinks that the mortgage crisis is preventing people from getting loans.
- **There are no trade organizations available to food cart vendors in Portland:** vendors' opinions about whether or not they would benefit from such an organization seem varied; one owner thought that vendors compete too much to want to work together, whereas several others felt that it would be beneficial.

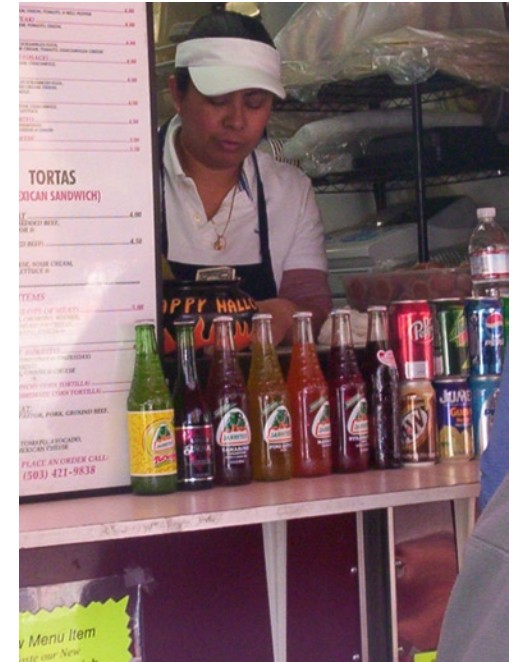

The cost of doing business comparison indicates the differences in market-entry for push carts, stationary mobile carts, and small businesses. It clearly demonstrates the difficulty of moving from even a successful food cart into a more stable storefront. This study found only one case of a business making the transition, although several cart businesses are at various stages of realizing that goal.

Sources: Portland Development Commission. (2007). Cost of Doing Business Estimator. (Retrieved 4/2008). Mercy Corps Northwest. (2008). Data from 2007 financial forecasts. Costs for push carts and food carts are based on average responses to Food Cartology vendor surveys and interviews.

Table 3: Cost of Doing Business Comparison

		Push Cart		Stationary Mobile Cart		Small Business	
Number of Employees		1	2	1	2	1	2
Range		Low	High	Low	High		
Revenues		\$10,000	\$20,000	\$30,000	\$50,000	\$48,999	\$97,998
Recurring Costs	Land Rent	\$0	\$0	\$6,000	\$7,200		
	Rent	\$100	\$100	\$0	\$0	\$11,186	\$22,372
	Storage	\$200	\$700	\$0	\$0	\$0	\$0
	Commissary Kitchen	\$500	\$4,200	\$0	\$0	\$0	\$0
	Workers' Compensation	\$0	\$0	\$0	\$0	\$990	\$1,980
	Total Recurring Costs	\$800	\$5,000	\$6,000	\$7,200	\$12,176	\$24,352
One-Time Costs	System Development Charges	\$0	\$0	\$0	\$0	\$1,511	\$3,021
	Cart (depreciated cost over 10 years)	\$200	\$600	\$600	\$3,000	\$0	\$0
	Total One-Time Costs	\$800	\$5,000	\$6,000	\$7,200	\$12,176	\$24,352
Building Permits		\$0	\$0	\$0	\$0	\$1,338	\$2,036
Taxes (State and Local Total)		\$100	\$100	\$100	\$100	\$214	\$294
Total Costs		\$1,100	\$5,700	\$6,700	\$10,300	\$15,239	\$29,703

Notes: The small business costs are based on the costs for a small storefront restaurant. The ranges show different costs that various carts may experience. For example, some low-end carts may incur higher-end expenses and vice versa. The one-time cart cost is depreciated over 10 years. Purchase costs range from \$2,000 for push carts to \$30,000 for stationary mobile carts regardless of financing.

Recommendations

The food cart industry will continue to operate in Portland for the immediate future. However, without some degree of planning for the future of carts, the public benefits and micro-enterprise opportunity they provide may be reduced, or even lost. The market for developable land heavily influences food carts' viability, and dictates how and where food carts can survive unless innovative strategies are employed to identify new ways to incorporate them into the urban fabric of Portland. Alternatively, over-regulating food carts can significantly reduce the community end economic benefits they provide.

UVG has developed three strategies to promote the beneficial aspects of food carts and mitigate negative impacts. Each of these strategies is comprised of several proposed actions that various city agencies could implement, which require varying levels of resource commitment. In some cases a partnership with existing community organizations is recommended, and particular organizations have been identified.

Portland's food carts are part of what makes Portland unique!
-Public Survey Respondent

The food carts are great addition to Portland's personality and the DIY attitude of the city's residents. I absolutely love them. They're right up there with the Farmers Market and Saturday Market in my book.

-Public Survey Respondent

Vision PDX

The Bureau of Planning is currently updating the Comprehensive Plan that will guide Portland's development over the next three decades. Promoting food carts will address all three central values of VisionPDX, a guiding document for the comprehensive plan.

Community Connectedness and Distinctiveness: providing funding and programmatic resources to strengthen the food cart sector will contribute to tightly-knit communities by providing avenues for social interactions, improving street vitality and safety. The colorful Mississippi carts are an indication of how diversity of cart design can add to a neighborhood's distinctiveness.

Equity and Accessibility: UVG found that food carts are often owned by immigrants, that the work is often satisfying and that many cart owners are able to support themselves and their families. Promoting this industry will therefore also expand economic opportunities among Portland's increasingly diverse population.

Sustainability: UVG's recommendations advance sustainability—**socially** through the personal interactions common at food carts; **environmentally** as they are usually accessed by non-automobile uses; **economically** by promoting local businesses and neighborhood retail areas; and **culturally** in their reflection of Portland's diversity.

Recommendations

Criteria

A wide variety of alternative actions to address the issues determined in the study were reviewed and evaluated against two types of criteria. First, the proposed action was evaluated on the basis of its ability to accomplish the project goals of promoting the benefits of food carts, mitigating impacts, and overcoming challenges. The second set of criteria evaluates political, financial, and administrative feasibility, answering the following questions:

Political Viability

Is the action acceptable or could it be made acceptable to relevant stakeholders?

Financial Feasibility

Do the benefits of the action justify the costs associated with implementing it?

Administrative Operability

Can the current agency staff implement and manage the action?

The analysis of the most favorable alternatives is shown in Table 4. UVG believes that the following recommendations are most effective and capable of being implemented based on our evaluation.

Strategy 1: Identify additional locations for food carts.

As the city matures and the market conditions that have facilitated food carts locating on surface parking lots begin to change, the City should identify additional locations where food carts can operate. All of the property owners interviewed indicated that they plan to develop the property when the market conditions are right, and the barriers

that exist usually preclude vendors from moving into the new retail spaces. Furthermore, the data indicate that finding a site is a barrier to opening a food cart, which will become increasingly more difficult as vacant lands are developed. It is in the City's best interest that food carts act as interim uses of vacant lands and not preclude development; however, this further diminishes the stability of cart sites. Furthermore, there are many existing public and private spaces that could benefit from the presence of food carts, especially to promote interim infill in commercial nodes outside the central business district. UVG recommends the following actions to expand options for food cart locations:

Action 1.1

Encourage developers to designate space for food carts in appropriate projects. As vacant lands are developed, working with developers to ensure that the public benefits associated with food carts are maintained will be important. Such spaces can help increase the stability of the location for the food cart owner and allow the developer to provide distinctive character to a project that is suitable for food carts.

Action 1.2

Work with neighborhood partners to identify privately-owned sites that could be adapted for food carts and are appropriate for such uses. Sites may include properties with existing shelter or electric hook-ups, space for seating, adequate pedestrian access, and market demand for additional small restaurant uses. Food carts should be especially considered in areas where they could make an area feel safer.

Recommendations

Action 1.3

Provide space for food carts in existing publicly owned locations and consider carts in projects currently under development. Food carts represent an opportunity for the City to provide avenues for local small business development in areas they may not otherwise be able to afford rent. Some examples of existing or proposed locations where food carts could be accommodated include: city parks, the downtown bus mall, MAX stops and transit centers, park and ride facilities, Ankeny Plaza, Centennial Mills, and sidewalks in popular commercial or high-pedestrian-volume districts. The Eastside light rail line is a good example of an opportunity with significant pedestrian traffic that would benefit from the presence of carts.

Strategy 2: Increase awareness of informational resources for stakeholders in the food cart industry by connecting them with existing programs.

The results of this study indicate that food cart owners do not appear to be accessing assistance currently available through existing programs and resources. Many small business programs such as Mercy Corps NW, Hacienda, and other non-profit organizations provide financial planning and other business development services. Cart owners or potential owners could benefit from business plan assistance, help finding a cart and location, guidance maneuvering the regulatory environment, and many other aspects of beginning a business. Such assistance could help increase the profitability of food cart businesses, increase the number of owners that are able to save money, and eventually help those that wish expand or transition to a storefront. UVG recommends the following actions to increase awareness of these resources among food cart owners:

Action 2.1

Partner with community organizations to develop an outreach strategy. Working with Mercy Corps NW, Hacienda, Immigrant and Refugee Community Organization, Community Development Corporations, and other community groups, identify existing and potential food cart entrepreneurs and inform them about existing programs that provide business assistance. Such assistance should include marketing, developing a business plan and financial planning, accessing grants, and navigating the permitting process. A variety of outreach tools could be used including developing a website or hosting a food cart fair, which would connect vendors, farmers, landowners, and small business support providers.

Action 2.2

Expand the business finance and incentive programs at PDC to include targeted support for food carts. Currently, programs provide many types of resources to traditional small business, which could also benefit food carts. PDC should expand their loan and assistance programs to specifically target food cart owners. This assistance could include helping food carts' start-up challenges and assisting them as they transition into storefronts. Assistance could include providing space for storage of additional goods needed for the move to a larger location and a savings program to aid financing the transition.

The trust of a city is formed over time from many, many little public sidewalk contacts. It grows by people stopping by at the bar for a beer, getting advice from the grocer and giving advice to the newsstand man, comparing opinions with other customers at the bakery...
-Jane Jacobs (1961)

Recommendations

Hacienda hosts a micro-enterprise program called Micromercantes. The project which started only last year has already created a buzz in local farmer markets. At fourteen weekly farmers markets, Micromercantes sells the best tamales in town. Seventeen women, mostly Latina single mothers, increased their household income by 25-30% by participating in the program. This year they will open a food cart downtown. The cart will be run by a cooperative of 14 women. Through the program they offer access to MercyCorp's 3-to-1 individual development account (IDA) match program, and business skills training. The staff at Hacienda are providing a key role by navigating many of the hurdles associated with opening a cart including finding a location, purchasing a cart, and getting licensed. Finding a commercial kitchen is also another commonly hurdle to opening a food cart and Hacienda is building a commercial kitchen at one of their affordable housing sites.

Strategy 3: Promote innovative urban design elements that support food carts.

Innovative urban design can promote the benefits of food carts while mitigating their negative impacts by implementing the following actions:

Action 3.1

Support publicly- or privately- provided food cart site improvements that increase public amenities. Such amenities could include seating, shelter, landscaping, and pedestrian-friendly sidewalks. The proposed awning and railing on the bus mall at SW 5th and Oak are examples of such improvements.

Action 3.2

Work with stakeholders to ensure an adequate supply of trash cans. Work with Multnomah County Health Department, private property owners, and/or food cart owners to ensure that sites have adequate trash cans at food carts.

Action 3.3

Sponsor a design competition to incorporate food carts uses on sites. A cost-efficient way of increasing awareness and promoting creative design, such a competition could develop ways of incorporating food carts or smaller retail niches that may be appropriate for cart owners who want to expand.

Action 3.4

Continue to support diversity in design regulations. Currently, the design of carts on private property is not regulated. Push carts on the public right-of-way that undergo design review have minimal design requirements. UVG's study found that the cart design did not influence either the public's perception of food carts or the level of social interaction. Therefore, the City should continue to allow the food carts to reflect design diversity.

Recommendations

Portland Transit Mall Revitalization Project

Over the past two years, Trimet's Block By Block (BBB) project has identified opportunities to make the mall safer, livelier and more economically vital. Food carts are a key ingredient in the mall's revitalization and one that will contribute to the activation and animation of downtown, according to a BBB report on street vending.²⁸

Based on research on food cart practices in Portland and other U.S. cities, BBB made four key recommendations for a new food cart program.²⁹

1. The food cart program should be managed and regulated by the non-profit Portland Mall Management Inc.(PMMI). Existing sidewalk push carts should continue to be regulated by the Portland Office of Transportation.
2. Food Carts should be established at seven prime locations that were identified by BBB.
3. Cart operators should be recruited from well-know restaurants and cafés, such as Papa Haydn's, Jake's and Moonstruck Chocolate's.
4. PMMI should lease "off the shelf" carts to vendors and modification should be limited to adding PMMI's logo as well as the cart company's name.

UVG applauds the food cart program as outlined above and recognizes it as a significant step in making the transit mall a vibrant social space. We do, however, recommend adapting the program in light of our findings in order to make the most of the \$200 million public investment in the Transit Mall Revitalization Project. We recommend the following two program adaptations:

1. The food cart program should consider economic equity as a central objective and recruit cart operators, not from high end restaurants, but from low income and minority communities.
2. Creativity in cart aesthetics should be encouraged, rather than limited, in order to allow vendors to creatively participate in the design of the urban fabric. UVG's results show that the aesthetics of a cart's exterior has little impact on the social benefits of the enterprise but may add to a neighborhood's distinctiveness.

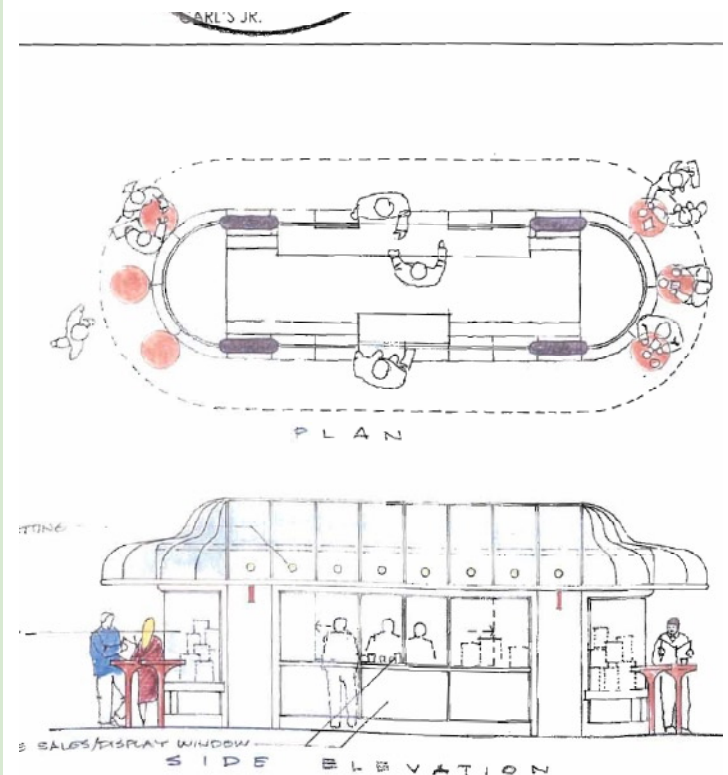

A proposed transformation of a 1980s bus shelter into a street vending space in the Transit Mall

Source: Block By Block

Recommendations

Innovative Design for Density and Carts

The mixed-use affordable housing development Hismen Hin-nu Terrace in Oakland, California, demonstrated how vending carts can complement high density development by incorporating vendor niches in its façade at street level. The architect Michael Pyatok included street vending in the design to create livelier, safer sidewalks and to provide entrepreneurial opportunities for the low income immigrant residents of the neighborhood. The sidewalk niches are recessed five feet from the sidewalk and roll-down curtains allow vendors to store their wares safely overnight. Unfortunately, the design was not flawless; views into the indoor retail space located behind these niches were blocked by the street vendors. With slight design modifications, the retail element of the award winning Hismen Hin-Nu Terrace could have been even more successful.²⁷ This project is a good example of ways that cities can foster spaces for food carts even after vacant lands and surface parking have been developed.



Vendor niches at Hismen Hin-Nu Terrace, Oakland, CA
Source: www.wallpa.uic.edu

Next Steps

This preliminary analysis of the food cart industry indicates additional research opportunities into ways that the City of Portland can assist or manage the food cart industry to achieve city-wide goals.

Food Access. Food carts may increase access to food in low-income neighborhoods, which may lack grocery stores or access to fresh fruits or vegetables. After identifying access to food as an equity issue for the City to address, New York made additional food cart permits available to carts that sell fresh produce in low-income neighborhoods. Portland could explore similar ways to increase food access by providing incentives for food carts to locate in target neighborhoods.

Rethinking Zoning. since the placement of mobile food carts on private land is unregulated by the zoning code, there is limited oversight or public involvement for the placement of such a site. The City may want to explore the possible ways to permit food cart sites, especially where several are located on one parcel. However, the City should be aware that increased regulation might be a distinct concern and potential barrier to carts

Recommendations

Table 4: Recommendation alternatives evaluation

ACTIONS		CRITERIA						
		Benefits Promotion	Impact Mitigation	Overcomes Challenges	Politically Viable	Financially Feasible	Administrative Operability	
STRATEGIES	Identify Additional Locations for Food Carts	Encourage developers to designate space for food cart operations in appropriate projects	X		X	X	X	X
		Work with neighborhood partners to identify privately owned sites that could be adapted for interim uses like food carts	X		X	X	X	
		Provide space for food carts in new or existing publicly owned locations	X	X	X	X		X
		Purchase and develop a property explicitly for food carts and other micro-enterprise businesses	X	X	X			
		Develop a referral system to connect property owners with space and food cart owners looking for a site	X		X			
	Increase awareness of informational resources for stakeholders	Partner with community organizations to develop an outreach strategy	X		X	X	X	X
		Expand the business finance and storefront improvement programs at PDC to include support for food carts and other micro-enterprises	X		X	X		X
	Promote Innovative Urban Design	Support publicly or privately provided food cart friendly site improvements that increase public amenities	X		X	X		X
		Sponsor a design competition to incorporate food carts on site	X		X	X	X	X
		Work with stakeholders to ensure an adequate supply of trash cans at food cart sites		X		X	X	X
		Continue to support diversity in design regulations	X			X	X	X

Notes:

1. Portland Food Carts: foodcartsportland.com, Food Cart Map: www.speakeasy.org/~aeschrigh/maps, Sellwood Corner Food Carts: myfoodcart.com, all accessed 5/26/2008
2. Chatty-Nougat Chew-Chew: Eat Mobile Gobbled up the Crowds Under the Fremont Bridge. Byron
3. Duin, Steve. The rules don't apply at this buffet line. *The Oregonian*. July 4, 2002
4. Mehta, Vikas(2007). Lively Streets: determining environmental characteristics to support social behavior. *Journal of Planning Education and Research* 27: 165-187; Jacobs, Jane (1961). *The Death and Life of Great American Cities*; Whyte, William. (1980). *The Social Life of Small Urban Spaces*. 52.
5. Mehta, Vikas, (2007).
6. Whyte (1980).
7. Duin, Steve. Crab and whine aren't on the menu. *The Oregonian*. 10/16/2007.
8. Portland Plan: "Comprehensive Plan" Evaluation by the Urban Form Technical Working Group, DRAFT report, March 25, 2008. p.19.
9. Portland Plan: Economic Development Assessment Report and Workplan Technical Working Group DRAFT, Feb. 19, 2008
10. Duin, Steve. The rules don't apply at this buffet line. *The Oregonian*. July 4, 2002
11. Oregon Economic and Community Development Department. Accessed 5/23/2008. <http://www.oregon4biz.com/smbiz.htm>
12. Portland Development Commission. Final Report: Portland Small Business Prosperity Strategy. (Retrieved May 23, 2008). (p. 3). http://www.pdc.us/pdf/bus_serv/pubs/portland_small_business_prosperity_strategy.pdf
13. Temali, Mihailo. (2002). *The Community Economic Development Handbook: Strategies and Tools to Revitalize Your Neighborhood*. Amherst H. Wilder Foundation. p.3.
14. http://streetvendor.org/public_html Accessed 2/15/2008
15. <http://www.nuestracdc.org/Village%20Pushcarts.html> Accessed 2/15/2008
16. Portland Plan: Economic Development Assessment Report and Workplan Technical Working Group DRAFT, Feb. 19, 2008, p.6.
17. Ibid, p.11.
18. Press Release from the City of New York. December 18, 2007. "Mayor Bloomberg and Speaker Quinn announce Green Cart Legislation to Improve Access to Fresh Fruits and Vegetables in Neighborhoods with Greatest Need."
19. City of Toronto. www.toronto.ca/business/alacart.htm. Accessed 5/3/2008.
20. Johnson, Gary. April 20th, 2007. Personal Interview. City of Seattle, Bureau of Planning.
21. Renaud, Jean-Paul. "For the Love of LA Taco Trucks." May 1st, 2008. *LA Times*.
22. Editorial, "Unwelcome Mat for Taco Trucks." August 15, 2000 *Oregonian*.
23. Morales, Alfonso. (2008) Planning for Street Markets and Street Merchants. Presentation to American Planners' Association Conference, 4/2008.
24. *Portland Monthly*, April 2008. Crime statistics based on Portland Police Bureau 2007 statistics. Crime defined as incidents of murder, rape/sodomy, molestation, robbery, aggravated assault, burglary, arson, auto and bike theft, larceny, and vandalism.
25. Coalition for a Livable Future. *Regional Equity Atlas*, 2007.
26. ESRI Business Analyst, 2007
27. Rudy Bruner Award for Urban Excellence, Silver Medal 1997.
28. January 24, 2007, p. 1 "Summary of Vendor Cart Investigations"
29. April 2, 2007. Portland Transit Mall Re-vitalization Project. "Final Vendor Cart Recommendations"

Appendix A-Regulatory Session Attendees

Richard Eisenhauer, Portland Office of Transportation, City of Portland

Kenneth Yee, Multnomah County Health Department, City of Portland

Randall Howarth, Multnomah County Health Department, City of Portland

Sterling Bennet, Bureau of Development Services, City of Portland

Kenneth Carlson, Bureau of Development Services, City of Portland

Suzanne Vara, Bureau of Development Services, City of Portland

Judy Battles, Bureau of Development Services, City of Portland

Kate Marcello, Bureau of Development Services, City of Portland

Mike Ebeling, Bureau of Development Services, City of Portland

Appendix B-Survey and Inventory Instrument

Site Inventory

Location:			Date/Time:			Name:					
Site											
Total Number of Carts On Site	Odor (1-3)	Smell Pleasant? (Y/N)	Noise (1-3)	Litter on Site (1-3)	# On Street Parking Available directly in front	# Of Off Street Parking on Site	Paved (Y/N)	Shaded Area Provided on site to sit(Y/N)	Side walk width(feet)	Block Side	Speed
PUBLICLY Provided Furnishings											
# of trash cans	#ofbenches	# of street trees		Other site improvements							
				Pedestriancrossingsafetyfeatures							

DEFINITIONS

Total Number of Carts On Site	Record the total number of Carts on the Site and others immediately adjacent	# Of Off Street Parking Available on Site	ApproximatethenumberofvehiclesthatcouldparkonsiteforFREE
Odor (1-3)	Rank the Odor of the entire site 1-No noticeable food smells 2-Mild food smells on site 3-Strong food smells across street or 50 feet away	Paved (Y/N) Shaded Area Provided on Site (Y/N) What is the side walk width? Block Side	Is the site paved? Is there a shaded area provided to sit under? In feet in front of carts What side of the block are the carts on? (N,S,E,W)
Smell Pleasant?	If odor is ranked 2 or 3. Are the food smells pleasant?	Speed	What is the posted speed limit on the street in front of the site?
Noise (1-3)	Rank the noise level of the entire site 1-No noticeable noise coming from site 2-Somenoisecomingfromsitethatadjacentneighborscan hear 3-You hear noise from the site from 50 feet away	Publicly provided furnishings Other site improvements Aretherepedestriancrossingsafetyfeaturesto the site--curb bulbs, crosswalks?	Recordnumberofpubliclyprovidedtrashcans,benchesandstreet trees on the block that the carts are located all four sides of block Listanyotherimprovements tothesiteincludinglaying down bark, flowers, benches, art.... Describepedestriansafetyaccessfeaturesthatprovideaccess to the site (curb bulbs, crosswalks)
Litter on Site (1-3)	Rank the amount of litter on the site (the entire block) 1- No noticeable litter 2- Less then 20 pieces of litter 3- More then 20 pieces of litter	OtherNotes:Plasenoteanyotherrelevantstreetdesign/publicamenitiesorpointsofinterestsurrounding the site:	
On Street Parking Available directly in front	NumberofSpaceavailableonthestreetdirectlyinfrontof blockthatcartsarelocated(allsidesoftheblockbothsides of the street)		

Appendix B-Survey and Inventory Instrument

Cart Inventory

Location:				Date/ Time:			Name:			
Carts										
	Awning (Y/N)	Porch (Y/N)	Garbage Can (Y/ N)	Side- walk Sign (Y/N)	Cart specific seating#	Exterior Aesthet- ics of Cart (1-3)	Water/ Gas Tank Visibility (Y/N)	Name of Owner	Survey Dropped Off (Y/N)	Survey Picked Up (Y/ N)

Definitions

Name of Cart

Record Name Of Cart

Exterior Aesthetics of
Cart (1-3)

Rank the aesthetics of the cart

Awning (Y/N)

Is there an awning that is
attached to the cart?

1-Cart is not maintained, visibly in disrepair, AND no art or
decoration

Porch (Y/N)

Is there a deck or porch?

2-Cart is maintained but no art or decoration

Garbage Can (Y/N)

Does the cart have a gar-
bage can?

3-Cart is maintained and attractive with decorations and art

Sidewalk Sign (Y/N)

Does the cart have a side-
walk sign?

Gas/Water Tank

Are the gas/water tanks clearly visible from the street? (Y/N)

Cart specific seating

Number of seats

** NOTES

Appendix B-Survey and Inventory Instrument

Public Intercept Survey



Portland State University
Master of Urban and Regional Planning
Food Cartology Student Group Project

Food Cart Survey (Public Intercept)

1. Do you purchase food from food carts?

No **1a. Why not? (Please check all that apply)**

<input type="checkbox"/> Concern about food safety	<input type="checkbox"/> Unappealing condition of cart
<input type="checkbox"/> Don't like the food options	<input type="checkbox"/> Nowhere to sit
<input type="checkbox"/> Don't like the owner/worker	<input type="checkbox"/> Waiting time is long
<input type="checkbox"/> Others (please specify) _____	

GO TO QUESTION #2

Yes **1b. How often do you patronize food carts?**

<input type="checkbox"/> 5 or more times a week	<input type="checkbox"/> 1 to 2 times a week
<input type="checkbox"/> 3 to 4 times a week	<input type="checkbox"/> Less than once a week

1c. Why do you patronize food carts? (Please check all that apply)

<input type="checkbox"/> Affordable food	<input type="checkbox"/> Close to work/school
<input type="checkbox"/> Tasty food	<input type="checkbox"/> Close to home
<input type="checkbox"/> Personal relation with cart operator	<input type="checkbox"/> Outdoor seating/table
<input type="checkbox"/> Good place for people watching	<input type="checkbox"/> No other food option nearby
<input type="checkbox"/> Others (please specify) _____	

1d. How do you usually travel to the food carts?

Walk Bike Transit Drive Other _____

To what extent do you agree or disagree with the following statements

1e. I have good relationship with one or more food cart operators
 Strongly agree Agree Neutral Disagree Strongly disagree

1f. I have met new people while patronizing food carts
 Strongly agree Agree Neutral Disagree Strongly disagree

1g. I have become better acquainted with people while patronizing food carts
 Strongly agree Agree Neutral Disagree Strongly disagree

1h. I have conversations with cart operator(s) other than ordering food
 Strongly agree Agree Neutral Disagree Strongly disagree

1i. I have conversations with other customers at the food carts
 Strongly agree Agree Neutral Disagree Strongly disagree

Please indicate to what extent you agree or disagree with the following statements.

2. The presence of food carts in this neighborhood makes the streets feel safer.
 Strongly agree Agree Neutral Disagree Strongly disagree

3. I want to see more food carts in this neighborhood
 Strongly agree Agree Neutral Disagree Strongly disagree

4. Food carts in this neighborhood are a better use of the site than a parking lot
 Strongly agree Agree Neutral Disagree Strongly disagree

A few more questions on the back

5. How do you feel about the following physical qualities of the food cart(s) in this neighborhood?

	Appealing	Unappealing	No opinion
5a. Signs	<input type="checkbox"/>	<input type="checkbox"/>	<input type="checkbox"/>
5b. Awnings	<input type="checkbox"/>	<input type="checkbox"/>	<input type="checkbox"/>
5c. Exterior of trailer	<input type="checkbox"/>	<input type="checkbox"/>	<input type="checkbox"/>
5d. View into kitchen	<input type="checkbox"/>	<input type="checkbox"/>	<input type="checkbox"/>
5e. Tables and chairs	<input type="checkbox"/>	<input type="checkbox"/>	<input type="checkbox"/>

6. Is there noticeable smell from the food cart(s)? Yes No Don't know

6a. How do you feel about the smell?
 Pleasant Neutral Unpleasant N/A

7. Is there noticeable noise from the food cart(s)? Yes No Don't know

7a. How do you feel about the noise?
 Pleasant Neutral Unpleasant N/A

8. Is there noticeable litter from the food cart(s)? Yes No Don't know

9. How do you think the food cart(s) can be improved? (Please check all that apply.)

<input type="checkbox"/> Better design of cart exterior/signage	<input type="checkbox"/> Operate more evening hours
<input type="checkbox"/> Appropriate handling of trash	<input type="checkbox"/> Operate fewer hours
<input type="checkbox"/> Appropriate waste water disposal	<input type="checkbox"/> Pedestrian clearance on sidewalk
<input type="checkbox"/> Safer food handling	<input type="checkbox"/> Provide bathroom
<input type="checkbox"/> Use recyclable food containers	<input type="checkbox"/> Provide seating/table
<input type="checkbox"/> Reduce odor	<input type="checkbox"/> Provide shelter from weather
<input type="checkbox"/> Reduce noise	<input type="checkbox"/> Nothing to improve
<input type="checkbox"/> Others (please specify) _____	

10. Of the above issues, which one are you mostly concerned with?

11. What is your overall perception of food cart(s) in this neighborhood?
 Very Positive Positive Neutral Negative Very Negative

12. What is your yearly household income?

<input type="checkbox"/> Less than \$15,000	<input type="checkbox"/> \$45,000-\$54,999
<input type="checkbox"/> \$15,000-\$24,999	<input type="checkbox"/> \$55,000-\$64,999
<input type="checkbox"/> \$25,000-\$34,999	<input type="checkbox"/> \$65,000-\$74,999
<input type="checkbox"/> \$35,000-\$44,999	<input type="checkbox"/> \$75,000 or more

13. Other comments or suggestions for our study?

Thank you for your time!

Appendix B-Survey and Inventory Instrument

Vendor Survey



Portland State University
Master of Urban and Regional Planning
Food Cartology Student Project
Site No. _____ Survey No

The Urban Vitality Group is made up of six students from Portland State University's Urban and Regional Planning program. We are studying the social and economic impacts of food carts in the city and would like your input based on your experience as a food cart owner. Your answers will be kept anonymous. Thank you for taking the 5-10 minutes to finish our survey!

Name of Business _____ Type of food _____
Business Address/Location _____

1. Why did you get into the food cart business, rather than another industry? (Check all that apply)

<input type="checkbox"/> a Flexibility of schedule	<input type="checkbox"/> c Hard to find other employment	<input type="checkbox"/> e Want to be a cook
<input type="checkbox"/> b Independence	<input type="checkbox"/> d Knew other cart owners	<input type="checkbox"/> f Want to have my own restaurant

g. Other reasons (please specify): _____

2. What year did you begin operating this cart? _____
Was your cart previously owned by a different owner? Yes No

3. How satisfied are you with your current location?

<input type="checkbox"/> a Very satisfied	<input type="checkbox"/> b Somewhat Satisfied	<input type="checkbox"/> c Neutral	<input type="checkbox"/> d Somewhat Unsatisfied	<input type="checkbox"/> e Very Unsatisfied
---	---	------------------------------------	---	---

What do you particularly like or dislike about your location? _____

4. What are your hours? (Check all that apply)

Weekdays		Weekends		Winter	
<input type="checkbox"/> a Breakfast	<input type="checkbox"/> c Dinner	<input type="checkbox"/> e Breakfast	<input type="checkbox"/> g Dinner	<input type="checkbox"/> i Breakfast	<input type="checkbox"/> k Dinner
<input type="checkbox"/> b Lunch	<input type="checkbox"/> d Late-night	<input type="checkbox"/> f Lunch	<input type="checkbox"/> h Late-night	<input type="checkbox"/> j Lunch	<input type="checkbox"/> l Late-night

5. How many employees do you have, not including yourself? _____ **How many are family members?** _____

6. What changes would you make to attract more customers? (Check all that apply)

<input type="checkbox"/> a Clean-up site around my cart	<input type="checkbox"/> d Provide seating/table	<input type="checkbox"/> g Advertise food
<input type="checkbox"/> b Provide recycleable food containers	<input type="checkbox"/> e Improve signage	<input type="checkbox"/> h Improve marketing
<input type="checkbox"/> c Improve access for pedestrians	<input type="checkbox"/> f Install awning	<input type="checkbox"/> i Create a website

Others (please specify): _____

7. Do you agree with the following statements?

Strongly Agree	Somewhat Agree	Neutral	Somewhat Disagree	Strongly Disagree	Does not apply
<input type="checkbox"/> 1	<input type="checkbox"/> 2	<input type="checkbox"/> 3	<input type="checkbox"/> 4	<input type="checkbox"/> 5	<input type="checkbox"/> 6
<input type="checkbox"/> 1	<input type="checkbox"/> 2	<input type="checkbox"/> 3	<input type="checkbox"/> 4	<input type="checkbox"/> 5	<input type="checkbox"/> 6
<input type="checkbox"/> 1	<input type="checkbox"/> 2	<input type="checkbox"/> 3	<input type="checkbox"/> 4	<input type="checkbox"/> 5	<input type="checkbox"/> 6
<input type="checkbox"/> 1	<input type="checkbox"/> 2	<input type="checkbox"/> 3	<input type="checkbox"/> 4	<input type="checkbox"/> 5	<input type="checkbox"/> 6

8. Did you face any of these difficulties when you were opening your business?

<input type="checkbox"/> a Obtaining financial support	<input type="checkbox"/> c Finding a trailer	<input type="checkbox"/> e Getting licences
<input type="checkbox"/> b Developing a business plan	<input type="checkbox"/> d Job training	<input type="checkbox"/> f Finding a site

Other (please specify): _____
What was difficult about it? _____

9. Did you receive any of the following types of assistance when starting your business?

a. Financial:	b. Business Experience:	c. Materials and Licenses:
<input type="checkbox"/> 1 Assistance from family members	<input type="checkbox"/> 1 Job training	<input type="checkbox"/> 1 Licenses
<input type="checkbox"/> 2 Support from an organization	<input type="checkbox"/> 2 Developing a business plan	<input type="checkbox"/> 2 Finding a trailer
<input type="checkbox"/> 3 Home equity loan		<input type="checkbox"/> 3 Finding a site
<input type="checkbox"/> 4 I used personal savings		

Other (please specify): _____

10. Do you currently have a business plan? 1 Yes 2 No 3 Don't know

11. Do you currently have a loan out on your business? 1 Yes 2 No 3 Don't know

12. What are your plans for the future of your business?

Expand:	Relocate:
<input type="checkbox"/> a Larger trailer	<input type="checkbox"/> d Within neighborhood
<input type="checkbox"/> b Additional cart	<input type="checkbox"/> e New neighborhood
<input type="checkbox"/> c Move into storefront	

Other (please specify): _____

13. If you plan to expand or relocate, what do you think might prevent you?

<input type="checkbox"/> a Lack of money
<input type="checkbox"/> b City regulations
<input type="checkbox"/> c Do not plan to expand or relocate

Other (please specify): _____

14. About how much do you spend each month on the following business expenses:

a. Rent? _____ b. Utilities? _____ c. Staffing? _____ d. Food costs? _____

e. Do you have a lease? 1 Yes; yearly 2 Yes; month-to-month 3 No 4 Don't know

15. Where do you buy your food?

<input type="checkbox"/> 1 Super market/ warehouse grocery (Costco)	<input type="checkbox"/> 3 On-site
<input type="checkbox"/> 2 Local farmer	<input type="checkbox"/> 4 Commissary kitchen

16. Where do you prepare your food?

1 _____ each month? _____

17. About how much money do you make each day? (gross total) _____

18. Do you agree with the following statements?

	Strongly Agree	Somewhat Agree	Neutral	Somewhat Disagree	Strongly Disagree	Does not apply
a. The food cart has been a good way for me to support myself and my family	<input type="checkbox"/> 1	<input type="checkbox"/> 2	<input type="checkbox"/> 3	<input type="checkbox"/> 4	<input type="checkbox"/> 5	<input type="checkbox"/> 6
b. I am able to put some money aside for a rainy day.	<input type="checkbox"/> 1	<input type="checkbox"/> 2	<input type="checkbox"/> 3	<input type="checkbox"/> 4	<input type="checkbox"/> 5	<input type="checkbox"/> 6

19. Do you own your home? Yes No

20. Do you have another job in addition to the cart? Yes; year-round Yes; seasonal No

21. How would you measure if your business is successful?

<input type="checkbox"/> 1 Many customers	<input type="checkbox"/> 3 Make a significant profit	<input type="checkbox"/> 4 Able to get by independently
<input type="checkbox"/> 2 Move into store front	<input type="checkbox"/> 5 Other: _____	

Demographic information

22. What is your ethnicity? 1 Hispanic 2 Caucasian 3 Asian 4 Eastern European 5 African American 6 Other _____

23. Were you born in the United States? 1 Yes 2 No a. How long have you lived here? _____ years

24. Where do you live?

<input type="checkbox"/> 1 Southeast Portland	<input type="checkbox"/> 3 Southwest Portland	<input type="checkbox"/> 5 North Portland
<input type="checkbox"/> 2 Northeast Portland	<input type="checkbox"/> 4 Northwest Portland	<input type="checkbox"/> 6 Outside city of Portland

25. Do you have any comments or suggestions for our study?

Thank you for your time!

Would you like to talk with us further about our study? _____ 2

Appendix B-Survey and Inventory Instrument

NOTE: Please ask the business owner or manager to complete this survey.

Date _____

Name of Business _____
Business Address _____
Type of Business (restaurant, dry cleaner, etc.) _____
How long has your business been in this location? _____
How many employees work in your business? _____

1. How often do you patronize the food cart(s) in this neighborhood?

- 1 5 or more times a week
- 2 3 to 4 times a week
- 3 1 to 2 times a week
- 4 Less than once a week
- 5 Never

Regarding the food carts in this neighborhood, please indicate to what extent you agree or disagree with the following statements.

2. The presence of food carts has increased foot traffic on the streets.

1 Strongly agree 2 Agree 3 Neutral 4 Disagree 5 Strongly disagree

3. My sales have increased because of the presence of food carts.

1 Strongly agree 2 Agree 3 Neutral 4 Disagree 5 Strongly disagree

4. The presence of food carts makes the streets feel safer.

1 Strongly agree 2 Agree 3 Neutral 4 Disagree 5 Strongly disagree

5. I have a friendly relationship with the food cart operators.

1 Strongly agree 2 Agree 3 Neutral 4 Disagree 5 Strongly disagree

6. I have a friendly relationship with other store-front business owners.

1 Strongly agree 2 Agree 3 Neutral 4 Disagree 5 Strongly disagree

7. I want to see more food carts in this neighborhood.

1 Strongly agree 2 Agree 3 Neutral 4 Disagree 5 Strongly disagree

8. Food carts are a better use of the site than a parking lot.

1 Strongly agree 2 Agree 3 Neutral 4 Disagree 5 Strongly disagree

9. Is there noticeable smell from the food cart(s)? 1 Yes 2 No 3 Don't know

10. Is there noticeable noise from the food cart(s)? 1 Yes 2 No 3 Don't know

11. Is there noticeable litter from the food cart(s)? 1 Yes 2 No 3 Don't know

9a. How do you feel about the smell?

- 1 Pleasant 2 Neutral 3 Unpleasant 4 N/A

10a. How do you feel about the noise?

- 1 Pleasant 2 Neutral 3 Unpleasant 4 N/A

12. How do you think the food cart(s) can be improved? (Please check all that apply.)

- | | |
|---|---|
| <input type="checkbox"/> a Better design of cart exterior/signage | <input type="checkbox"/> h Operate more evening hours |
| <input type="checkbox"/> b Appropriate handling of trash | <input type="checkbox"/> i Operate fewer hours |
| <input type="checkbox"/> c Appropriate waste water disposal | <input type="checkbox"/> j Pedestrian clearance on sidewalk |
| <input type="checkbox"/> d Safer food handling | <input type="checkbox"/> k Provide bathroom |
| <input type="checkbox"/> e Use recyclable food container | <input type="checkbox"/> l Provide seating/table |
| <input type="checkbox"/> f Reduce odor | <input type="checkbox"/> m Provide shelter from weather |
| <input type="checkbox"/> g Reduce noise | <input type="checkbox"/> n Nothing to improve |
| <input type="checkbox"/> o Others (please specify) _____ | |

13. Of the above issues, which one are you mostly concerned about?

14. Please rank your overall perception of food cart(s) in this neighborhood.

- 1 Very positive
- 2 Positive
- 3 Neutral
- 4 Negative
- 5 Very negative

15. Other comments or suggestions for our study?

Thank you for your time!

Appendix C-Interviewee List

Stakeholder Group	Organization	Representative Name
Private Property Owner (Downtown)	City Center Parking	Mark Goodman
Private Property Owner (Sellwood)	Sellwood Antique Mall	Mark Gearhart
Private Property Owner (Mississippi)	Mississippi Rising LLC	Rachel Elizabeth
Private Property Owner (Cully)	Cully Owner	Gerald Kieffer
Food Trailer/Cart Owner (Pioneer Square)	Shelly's Garden: Honkin' Huge Burritos	Shelly Sandoval
Food Trailer/Cart Owner (Downtown)	Loco Locos Burritos	Ana Maria
Food Trailer/Cart Owner (Downtown)	Tabor	Monika Vitek
Food Trailer/Cart Owner (Downtown)	Rip City Grill	Clint Melville
Food Trailer/Cart Owner (Sellwood)	Garden State Foods	Kevin Sandri
Food Trailer/Cart Owner (Sellwood)	Wild Things	Rick
Food Trailer/Cart Owner (Miss)	Tita's Pista	Judith Stokes
Food Trailer/Cart Owner (Miss)	Moxie Rx	Nancye Benson
Food Trailer/Cart Owner (Cully)	Taqueria Uruapan	Unknown
Food Trailer/Cart Owner (Cully)	Taquería Mendoza	Unknown
Neighboring Business Owner (Downtown)	Avalon Vintage	Paul Bassett
Neighboring Business Owner (Downtown)	The City Sports Bar	Tim Pearce
Neighboring Business Owner (Sellwood)	Elinas	Gary Craghead
Neighboring Business Owner (Miss)	Lovely Hula Hands	Sarah Minnick
Neighboring Business Owner (Cully)	Taqueria Ortiz	Gilberto Ortiz
Neighboring Business Owner (Other)	Tiny's Coffee	Tom Pena, Nicole Pena, Rachael Creagar
Restaurant Owner	Tio's Tacos	Pedro Rodriguez
Regulatory	PDC	Kevin Brake
Regulatory	BDS	Joe Botkin
Regulatory	BDS	Lori Graham
Regulatory/Financial	PDC (former Albina Comm. Bank)	Stephen Green
Regulatory	State of Oregon, Building Codes	Ernie Hopkins
Regulatory/Public Health	Multnomah County Health Department	Ken Yee
Micro enterprise	Mercy Corps	Sarah Chenven
Micro enterprise	Hacienda	Suzanne Paymar
Urban Design	Bureau of Planning	Mark Raggett
Urban Design	Private Consultant	Tad Savinar
Business Development	Alliance of Portland Business Associations	Jean Baker
Portland Street Vending History	Gatto & Sons	Auggie Gatto

Appendix D-Team Profile

HANNAH KAPELL

A native of Plymouth, Massachusetts, Hannah moved to Portland to study anthropology at Reed College. She joined the MURP program in Fall 2006 to focus on bicycling and sustainable transportation planning. Hannah is currently interning at Alta Planning + Design, where she is conducting a statistical analysis of the Safer Routes to School three-year program. She is also a graduate research assistant in the Intelligent Transportation System Lab, working on a project to determine the freight industry's effects of congestion in Oregon.

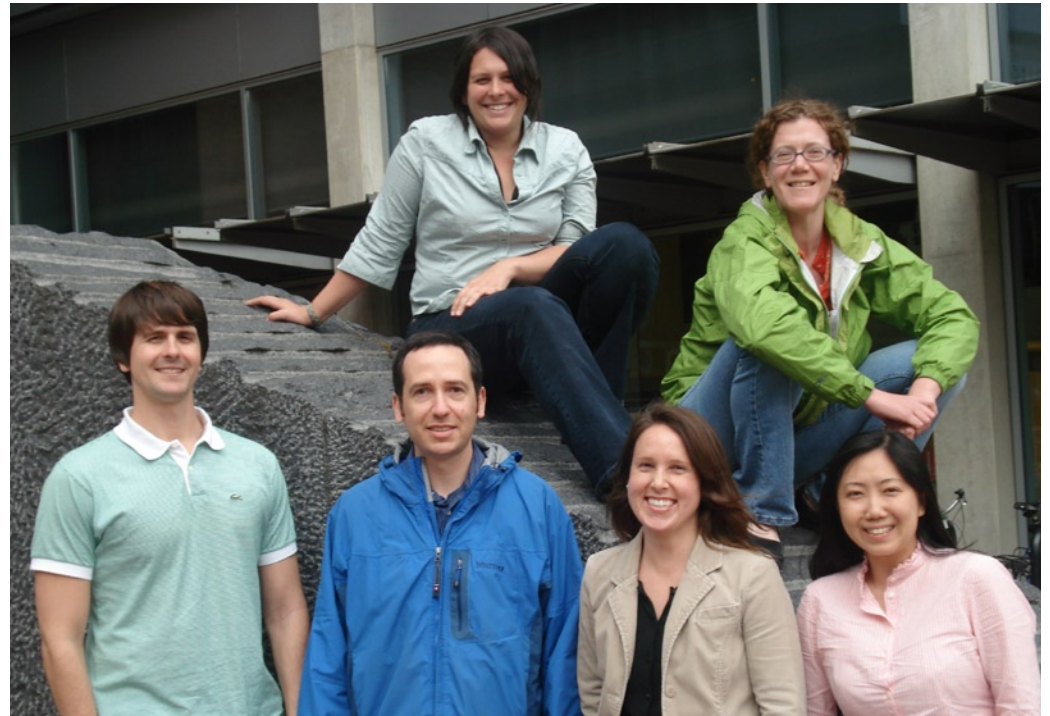

AMY KOSKI

Amy is interested in the role of small businesses in creating vibrant local economies. Recently, she worked as an intern at the City of Portland, Bureau of Planning conducting work on the Commercial Corridor Study. She is a graduate research assistant for the Institute of Portland Metropolitan Studies, where she compiled data for the Oregon Innovation Council to inform a statewide economic study and contributed to the Metropolitan Briefing Book 2007. Currently, she is working on a regional food systems assessment. This past fall, Amy studied in Argentina for five months where she had the opportunity to work with the indigenous population and worker-owned cooperatives.

PETER KATON

A native Portlander, Peter is a graduate of Lewis & Clark College with a Bachelor's degree in Psychology. After working for several years in community mental health and employment services, Peter joined the MURP program in Fall 2006. Currently an intern with the non-profit Growing Gardens, he assists with program development, resource acquisition and community outreach. With a keen interest in social justice, Peter is a founding member and secretary of the student group Planning Includes Equity. Outside of his studies, Peter enjoys gardening with native plants and is active in a local effort to bring innovative means of exchange to Portland that supports the triple bottom line.

Appendix D-Team Profile

JINGPING LI

A native of China, Jingping used to work as program officer in China's Ministry of Land and Resources, focusing on land use and natural resource management issues. She joined the MURP program in Spring 2006 with an interest in environmental planning and sustainability. As a Graduate Research Assistant, Jingping is actively involved in the China-U.S. Sustainable Land Use and Urban Planning Program housed in the College of Urban and Public Affairs that also partners with the International Sustainable Development Foundation.

KAREN THALHAMMER

Karen worked as a policy campaign coordinator in San Diego where she worked to pass a living wage ordinance for the City of San Diego. While there, she also organized a labor, housing, and environmental coalition to negotiate on planning policy and development projects. At the Community Alliance of Tenants she served as the Housing Policy Director and worked on a successful campaign to require that 30% of TIF be spent on affordable housing. This work lead her to PSU to work towards the MURP degree and Certificate in Real Estate Development. Most recently Karen worked at the Portland Development Commission. Currently she is the National Association of Realtors Fellow and authors articles on the housing, office, and retail market for the PSU Center of Real Estate Quarterly Report.

COLIN PRICE

Prior to joining the MURP program in Spring 2006, Colin worked as a consultant on environmental planning and site assessment projects in Arizona, San Francisco, and Portland. Currently, he works as a planner for Portland State University's Housing and Transportation Services where he is responsible for conducting and analyzing campus transportation surveys, managing PSU's transportation and housing-related Business Energy Tax Credit applications, and is involved with sustainable transportation research. Colin has also worked as a research assistant at the Institute of Portland Metropolitan Studies developing the Measure 37 claims database and regional food system assessment projects. His interests include creating resilient, equitable communities, examining the intersection of rural and urban interests, and understanding the role of public health in planning.